

FASTENER TECHNICAL DATA AND CHARTS SECTION

IMPORTANT DISCLAIMER

All of the information provided in this section has been assembled with concern for accuracy.

It is intended for advisory purposes only and use of this information is completely voluntary.

We do not guarantee its completeness or validity and assume no responsibility for any loss, claims or damages resulting from use or application of this information.

All information is subject to change without prior notice.

BE SURE TO VERIFY!

INDUSTRY STANDARDS AND SPECIFICATIONS

INDUSTRY STANDARDS

Most industrial fasteners are covered by two basic standards: one for materials and properties; the other, for dimensions and tolerances. Specifications for materials and properties are published by the American Society for Testing and Materials (ASTM), although other groups such as the Society of Automotive Engineers (SAE) also publish specifications covering these requirements.

Standards for dimensions and tolerances are issued by the American National Standards Institute (ANSI) in cooperation with the American Society of Mechanical Engineers (ASME) and the Industrial Fasteners Institute (IFI).

Where applicable, published specifications covering a particular fastener will be referenced in the section of this booklet dealing with that fastener.

When referring to standards and specifications, we will use only the well-known initials of the above societies-ANSI, ASME, IFI, ASTM and SAE.

Standard fasteners are basic industrial fasteners - square and hex bolts, cap screws, carriage bolts, plow bolts, lag screws, studs, nuts, rivets and others - which have been standardized over the years as to type, style, usage, properties, dimensions and tolerances.

These include a vast range of sizes and types stocked by distributors and manufacturers for an almost limitless range of applications: the assembly and maintenance of vehicles, appliances, farm equipment, construction equipment, industrial and plant machinery of all kinds, furniture and toys.

Wherever there's a need for holding parts together, holding them apart, holding them up, or holding them down, a standard fastener can usually be found to do the job efficiently and economically.

Modern industrial fasteners are manufactured to a variety of standards covering dimensions, tolerances, materials, mechanical properties, testing procedures, etc.

BASIC FASTENER TYPES

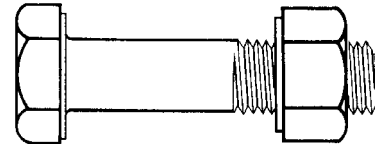

A **Bolt** is a device with a head on one end of a shank or body and a thread on the other end. Designed for insertion through holes in assembly parts, it is mated with a tapped nut. Tension is normally induced in the bolt to compress the assembly by rotating the nut. This may also be done by rotation of the bolt head.

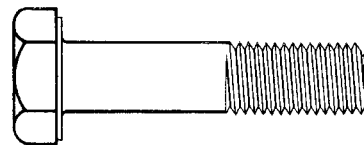

A **Screw** is a headed and threaded bolt used without a nut. It is inserted into an internally tapped hole and tension is induced by rotation of the screw head.



A **Stud** is a fastener with no head but it has threads at both ends of the shank. It, like a screw, has one end that screws into a tapped hole. A nut is used on the other end to create tension.

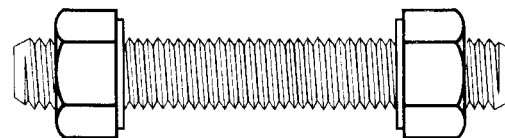

If a stud is threaded its entire shank length and a nut used on both ends to create tension, it serves the function of a bolt and is then classified as a **Stud Bolt**.

BASIC FASTENER DATA

TERMINOLOGY AND MEASUREMENTS

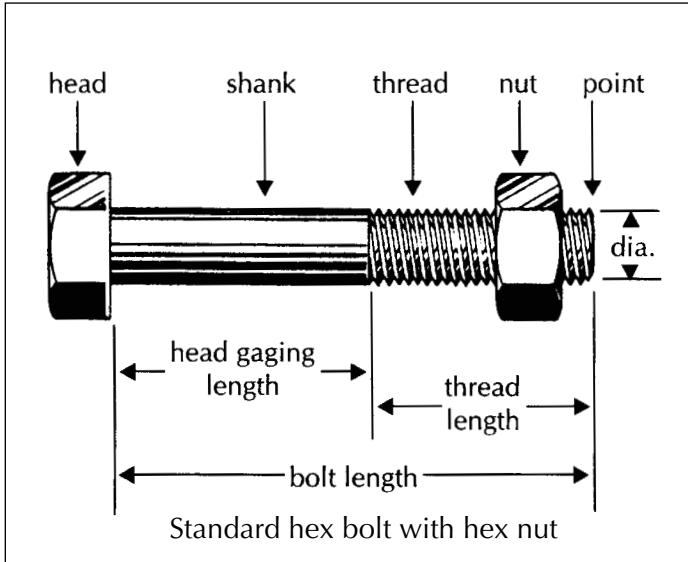

STYLES OF HEAD

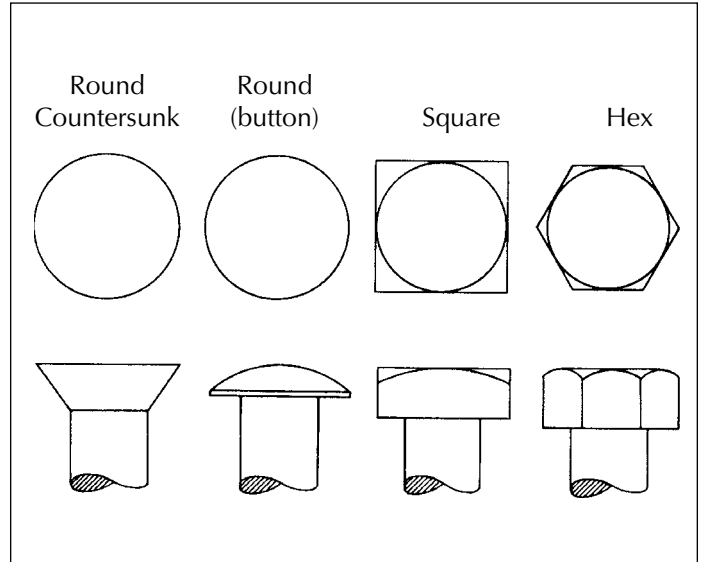

The diameter of all bolts is measured as the outside of major diameter of the thread. The length of a headed bolt is measured from the largest diameter of the bearing surface of the head to the extreme end of the point in a line parallel to the axis of the bolt. For example, square or hex head bolts are measured from under the head to the end of the bolt; a bolt with a countersunk head is measured overall. The point of a bolt is always included in the measured length. Headless fasteners such as studs are measured overall, including points, except for continuous-thread alloy studs made to ASTM Specification A193. This type is measured from first thread to first thread.

Bolts have various styles of heads. Some of the more popular styles are illustrated above.

HEAVY HEADS AND NUTS

Bolt users may require a bolt head or nut of greater width to compensate for wide clearance in bolt holes or unusually heavy loading. For such needs we offer heavy bolt heads and nut sizes. Heavy nuts are quite common and readily available in various types and sizes but heavy head bolts have more limited availability.

BOLT AND NUT BEARING SURFACES

Cold-upset bolts made on a "boltmaker" usually are washer faced but large or very long bolts may have a flat face (not machined). Nuts made on cold "nut-formers" may have double chamfered or washer faces. Large size nuts have hot-forged washer bearing faces, not machined, unless specially ordered.

FASTENERS

MASONRY
ANCHORSDRILLS/SAWS
& ABRASIVESTOOLS &
ACCESSORIESCONTRACTOR
& INDUSTRIALSAFETY
PRODUCTSCHEMICALS
& JANITORIALAUTO &
ELECTRICALSTRUT &
HANGERS

HEAT TREATMENT

Heat treatment covers various techniques that may be used to develop certain end-product characteristics. Customary procedures for fasteners include annealing, stress relieving, case hardening, direct quench and temper, and carbon restoration.

ANNEALING

A thermal cycle involving heating to, and holding at a suitable temperature and then cooling at a suitable rate, for such purposes as reducing hardness, improving machinability, facilitating cold working, producing a desired microstructure, or obtaining desired mechanical or other properties.

STRESS RELIEVING

A thermal cycle involving heating to a suitable temperature, usually 1000/1200°F, holding long enough to reduce residual stresses from either cold deformation or thermal treatment, and then cooling slowly enough to minimize the development of new residual stresses.

CASE HARDENING

A term descriptive of one or more processes of hardening steel in which the outer portion, or case, is made substantially harder than the inner portion, or core. Most of the processes involve either enriching the surface layer with carbon and/or nitrogen, usually followed by quenching and tempering, or the selective hardening of the surface layer by means of flame or induction hardening.

QUENCHING AND TEMPERING

A thermal process used to increase the hardness and strength of steel. It consists of austenitizing, then cooling at a rate sufficient to achieve partial or complete transformation to martensite. Tempering should follow immediately, and involves reheating to a temperature below the transformation range and then cooling at any rate desired. Tempering improves ductility and toughness, but reduces the quenched hardness by an amount determined by the tempering temperature used.

MECHANICAL PROPERTIES

Standard industrial fasteners are manufactured from either carbon or alloy steels.

When strength requirements are moderate, low-carbon steel is used.

High-strength fasteners are made from medium-high carbon or alloy steels and are heat treated to develop desired properties.

Most fasteners are covered by specifications that define required mechanical properties such as tensile strength, yield strength, proof load, and hardness.

TENSILE STRENGTH

The maximum tensile stress in pounds per sq. in. which a material is capable of sustaining, as developed by a tension test.

YIELD STRENGTH

The stress at which a material exhibits a specified deviation from the proportionality of stress to strain. The deviation is expressed in terms of strain, and in the offset method, usually a strain of 0.2 percent is specified.

PROOF LOAD

The point to which a material may be stressed without evidence of permanent deformation.

HARDNESS

The resistance of a material to plastic deformation. Usually measured in steels by the Brinell, Rockwell, or Vickers indentation-hardness test methods.

SCREW THREADS

FASTENERS

MASONRY
ANCHORSDRILLS/SAWS
& ABRASIVESTOOLS &
ACCESSORIESCONTRACTOR
& INDUSTRIALSAFETY
PRODUCTSCHEMICALS
& JANITORIALAUTO &
ELECTRICALSTRUT &
HANGERS

THREAD FORMS

Screw threads are spiral grooves produced on the outside of a bolt (external threads) or machined inside a nut (internal threads). Four thread forms have been established by the ANSI: UN (internal and external threads), UNR (external threads only), UNK (external threads only), UNJ (internal and external threads).

CUT VS. ROLLED THREADS

The terms “rolled thread” and “cut thread” refer solely to the physical characteristics of commercial bolts or studs, not to the method of thread production. A cut-thread bolt has a shank diameter equal to the threaded diameter; a rolled-thread bolt has a shank diameter less than the threaded diameter.

CLASSES OF THREAD FIT

Classes of thread fit are distinguished from each other by the amounts of tolerance specified. Classes 1A, 2A, and 3A apply to external threads; Classes 1B, 2B and 3B, to internal threads.

Classes 1A and 1B are shown in ANSI standards but are rarely used. Most standard fasteners are produced with a Class 2A fit for bolts and a Class 2B fit for nuts. The Class 2A allowance assures easier assembly of mating parts, minimizes galling and seizing in high-cycle wrench assembly, and can be used to accommodate commercial electroplated finishes. Classes 3A and 3B afford no allowance or clearance for mating parts and are used chiefly for applications where a close tolerance fit is important.

Class 5 is a special interference fit which results in an actual overlap of dimensions when threaded parts are fitted together. It is normally used only on the tap-end of studs. Threading requirements are designated (1) by the number of threads per inch applied to a specific diameter; (2) by the initial letters of the thread standard (UNR or UN); (3) by the letters C, F, or numeral 8 to indicate coarse-, fine-, or 8-thread series; and (4) by the thread fit. The following example illustrates the method of designating a screw thread:

<p>1/2 in. -13 UNRC-2A where 1/2 in. = nominal diameter of thread 13 = number of threads per inch UNR = thread form standard (Unified National Radius-Root) C = coarse-thread series 2A = class of thread fit</p>

The coarse-thread series (UNRC or UNC) is used on the vast majority of bolts and nuts. Number of threads per inch ranges from 20 threads for a 1/4-in.- diameter bolt to 4 threads for a 4-in.-diameter bolt. The fine-thread series (UNRF or UNF) is found mostly in automotive and aeronautical work. Threads per inch range from 28 threads for a 1/4-in.-diameter bolt to 12 threads for a 1-1/2-in.-diameter bolt. There is no fine-thread standard for fasteners over 1-1/2 in.

The 8-thread series (8UNR or 8UN) is used only for sizes over 1 in. in diameter, usually in high-temperature, high pressure service.

STANDARD STAINLESS STEEL SPECIFICATIONS

Type 301: Cr. 18, Ni. 8 (18-8 type), austenitic, hardenable by cold work only; t.s., 80-270,000 psi; y.s. 30-240,000 psi.; elongation in 2 in., 40-5%. In rods, bars, billets, wire, sheet, plate, strip and tubing. For parts requiring good corrosion resistance combined with high tensile strength and good ductility.

Type 302: Cr. 18, Ni. 8 (18-8 type), austenitic, hardenable by cold work only; t.s. 80-250,000 psi.; y.s. 30-225,000 psi.; elongation in 2 in., 60-5%; fair machinability excellent cold forming and welding properties. Furnished in sheet, strip, plate, bar, rod, forging billets and tube rounds, tubing, cold drawn shapes and structural shapes. For parts in acid handling food and dairy equipment; shafting, bearing plates, heat exchanger tubes, hydraulic tubing, piston rods, plungers, etc.

Type 303: Cr. 18, Ni. 8 (18-8 type), austenitic, hardenable by cold work only; t.s., 80-200,000 psi.; y.s. 30-135,000 psi.; elong. in 2 in. 55-10%; good machinability; fair cold forming and welding properties. In sheet, strip, plate, bar, rod, forging billets, tube rounds, tubing, cold drawn and structural shapes. For working parts in pumps and valves which must resist corrosion; screw machine parts requiring strength, good corrosion resistance.

Type 304: Cr. 18, Ni. 8 (18-8 type), austenitic, hardenable by cold work only; t.s., 85-250,000 psi; y.s., 30-225,000 psi; elongation in 2 in. 60-5%; slightly better corrosion resistance than Type 302. Furnished in rods, bars, billets, wire, sheet, plate strip, tubing and castings. For parts in chemical equipment such as shafting, bearing plates, heat exchanger tubes, etc.

Type 309: Cr. 25, Ni. 12 (25-12 type), austenitic, hardenable by cold work only; t.s., 95-190,000 psi.; y.s. 45-165,000 psi.; elong. in 2 inches, 50-5%; resists scaling to 2000°F, fair machinability, good cold C forming properties, excellent weldability. Furnished in sheet, strip, plate, bar, rod, forging billets, tube rounds, tubing, cold drawn shapes and structural shapes. For parts that must operate continuously at high temperatures; oil burner parts, furnace parts, heat exchangers, air heaters, baffle plates, etc.

Type 310: Cr. 25, Ni. 20 (25-20 type), austenitic, hardenable by cold work only; t.s., annealed, 70-155,000 psi.; elong. in 2 in., 55-5% good weldability, drawing, stamping properties; fair machinability. In sheet, strip, plate, bar, rod, forging billet, tube rounds, tubing, cold drawn, structural shapes. For parts subject to intermittent heating and cooling; oil burner parts, heat exchangers; dye house, paper mill, chemical equipment.

Type 316: Cr. 18, Ni. 12, No. 3 (18-12-3 type), austenitic, hardenable by cold work only; t.s., 80-170,000 psi; y.s., 35-150,000 psi; elong. in 2 in., 55-5% fair machinability; excellent welding, cold forming properties. Best creep strength at high temp. and best corrosion resistance of all grades. In sheet, strip, plate, bar, rod, forging billets, tube rounds, tubing, cold drawn and structural shapes.

Type 321: Cr. 18, Ni. 8, Ti. 4 x C min.; austenitic hardenable by cold work only; t.s., 80-170,000 psi.; y.s., 30-145,000 psi.; elong. in 2 in., 55-5%; fair machinability, excellent welding and cold forming properties. In sheet, strip, plate, bar, rod, forging billets, tube rounds, tubing, cold drawn shapes, structural shapes. For welded parts not annealed after welding or which operate at 800-1200°F; aircraft engine exhaust rings, flanges, etc.

Type 347: Cr. 8, Ni. 18, Cr. 8 x C min.; austenitic, hardenable by cold work only; t.s. 80-170,000 psi.; y.s., 30-150,000 psi.; elong. in 2 in. 50-5%; fair machinability, excellent welding and cold forming properties. In sheet, strip, plate, bar, rod, forging billets, tube rounds, tubing cold drawn and structural shapes. For welded parts not annealed after welding or which operate at 800-1200°F; aircraft engine exhaust rings, flanges, etc.

Type 410: Cr. 12 (straight chromium type), hardenable by heat treatment; t.s., 60-180,000 psi; y.s. 30-160,000 psi.; elong. in 2 in., 30-15%, good machinability, cold forming properties; good welding properties when annealed; most popular forging grade. In sheet, strip, plate, bar, rod, forging billets, tube rounds, tubing, cold drawn and structural shapes. Used where corrosion not severe, for bolts, nuts, shafting turbine blading, valve trim, heat treated parts; where hardness, toughness, desired.

Type 416: Cr. 12 (straight chromium type with sulphur or selenium added); excellent machinability; t.s., 70-170,000 psi; y.s., 4-140,000 psi; elong. in 2 in. 30-10%; fair cold forming properties, fair corrosion resistance. In bar, rod, forging billets, wire, cold drawn shapes. For mass production machined parts; Carburetor, instrument and electrical parts; screw machine parts.

Type 420: Cr. 13, C. 35; a widely used stainless cutlery steel. In the hardened and tempered condition, it combines an adequate hardness and cutting edge with good flexibility. It retains a bright polished finish and can be hardened to Rockwell C55. Maximum corrosion resistance is obtained in the hardened condition.

Type 420F: Cr. 13, C.35; free machining; has sulphur intentionally added to the base Type 420 analysis to make it easier to machine, grind and polish. Type 420°F has practically the same mechanical hardness, and corrosion resisting properties as Type 420.

Type 430: Cr. 17 (straight chromium type), non-hardenable by heat treatment; resists scaling to 1500°F; excellent cold heading properties, excellent machinability; does not discolor in atmosphere. t.s., 60-85,000 psi.: y.s. 35-55,000 psi.; elongation in 2 in. 35-20%. Furnished in sheet, strip, plate, bar, rod, forging billets, tube rounds, tubing, cold drawn shapes and structural shapes. For press plates, oil burner parts, screw machine parts, trim for automobiles such as body moldings, hub caps, finishing washers, gas tank caps, etc.; also trim for appliances.

Type 430F: Cr. 17 with 0.07 S. or Se.; straight chromium free machining type, non-hardenable by heat treatment; t.s., 60-85,000 psi.: 35-55,000 psi.: elong. in 2 in., 25-10% excellent machinability, fair cold forming properties. In forging billets, hot-rolled and cold-finished bars, wire and polished shafting. Particularly suitable for parts requiring considerable machining and only moderate corrosion resistance; screw machine parts.

Type 431: Cr. 16, Ni. 2 (straight chromium type), hardenable by heat treatment: t.s., 110-200,000 psi.; 80-150,000 psi.; elongation in 2 in., 20-15%; good machinability; fair cold forming properties: resists scaling to 1500°F. Best corrosion resistance of all hardenable stainless steels. Furnished in sheet, strip, plate, bar, rod, forging billets, tube rounds, tubing, cold drawn shapes, structural shapes. For parts requiring excellent physical properties coupled with high corrosion resistance.

Type 440 C and 440 A, B and C: Cr. 17, C 1.00 (straight chromium type) hardenable by heat treatment: t.s., 110-285,000 psi; 60-275,000 psi.: elong. in 2 in., 15-21%; fair machinability, cold forming properties. Types A, B, same analysis except for lower carbon content: less hardenable; Type F, free machining. In sheet, strip, plate, bar, rod, forging billets, tube round tubing, cold drawn and structural shapes; needle, ball check valves; ball bearings, scissors, rules, cutlery, etc.

Types 501 and 502: Type 501, 4/6 Cr. plus Mo. over .10 C. Type 502, 4/6 Cr. plus Mo., over .10 C. maximum. Both types are recommended for use in the petroleum industry. In refinery equipment, particularly where sour crudes are encountered, a life of four to ten times that of mild steel is not uncommon. These alloys are suitable for use at slightly elevated temperatures, and are more resistant to scaling or oxidation than mild steel. Scaling temperature about 1150° Fahrenheit.

FASTENERS

MASONRY
ANCHORSDRILLS/SAWS
& ABRASIVESTOOLS &
ACCESSORIESCONTRACTOR
& INDUSTRIALSAFETY
PRODUCTSCHEMICALS
& JANITORIALAUTO &
ELECTRICALSTRUT &
HANGERS

FASTENERS
MASONRY ANCHORS
DRILLS/SAWS & ABRASIVES
TOOLS & ACCESSORIES
CONTRACTOR & INDUSTRIAL
SAFETY PRODUCTS
CHEMICALS & JANITORIAL
AUTO & ELECTRICAL
STRUT & HANGERS

BRASS

DESCRIPTION:

Brass, composed nominally of Copper and Zinc, is the most common copper-base alloy. Its uses are myriad since it is relatively inexpensive, is easily worked into any shape or form and possesses strength, toughness and good corrosion resistance.

CHARACTERISTICS:

Cold drawn Brass has an even greater tensile strength than mild Carbon Steel. It is both tough and malleable, qualities that make it particularly desirable for fasteners. It is immune to rust with generally high resistance to corrosion. It takes a high, lustrous finish and is non-magnetic.

USES:

Fastenings made from Brass and related alloys are widely used in electrical communications equipment, builders' hardware, marine hardware, a wide variety of out-of-doors assemblies, uncountable consumer, industrial and scientific products and for general use where a rustproof bolt or screw is required.

SILICON BRONZE

DESCRIPTION:

Silicon Bronze is the generic term used for various types of Copper-Silicon alloys. The most common of these are Everdur, Duronze, Herculoy, PMG Metal and Olympic Bronze. The properties of these trade named alloys are all basically the same with high percentages of Copper and small amounts of Silicon, Manganese or Aluminum added for strength. Lead is also added for free machining qualities where required.

CHARACTERISTICS:

Silicon Bronze possesses high tensile strength superior to mild Steel. It has high resistance to corrosive influences such as extreme temperatures, atmospheric conditions, natural and sea water, gases and sewage. It is non-magnetic and has excellent machining and working characteristics.

USES:

Pole line hardware, switchgear equipment, sewage disposal, marine applications, water meters, valves and systems, chemical, plumbing and liquid handling equipment, food machinery, petroleum processing and all applications where exposure to the elements is a factor.

STAINLESS STEEL

DESCRIPTION:

Stainless Steels are broadly defined as Iron alloys containing from 12 to 30% Chromium and from 0 to 20% Nickel. This analysis is further modified by additions of Carbon and other minor elements which contribute specific effects either to control mechanical properties or to improve corrosion resistance. The corrosion resistance of Stainless Steels is attributed to a surface phenomenon, passivity. When oxygen comes in contact with the surface it forms an invisible film which protects the underlying metal from rusting and corrosion under severe environment.

CHARACTERISTICS:

The family of Stainless Steels is divided into three general classifications: "Austenitic" Stainless Steels make up the general group of the 18-8 (or 300) series. They are the Chromium-Nickel type containing upwards of 8% Nickel. They are not hardenable by heat treatment, non-magnetic for practical purposes and offer the greatest degree of corrosion resistance. "Martensitic" Stainless Steels contain from 12 to 20% Chromium. They are magnetic and hardenable. Type 410 and 416, common fastening alloys, are Martensitic Stainless Steels. "Ferritic" alloys are also Chromium Stainless Steel alloys. They are magnetic and not hardenable by heat treatment. Type 430 is an example.

USES:

There are almost as many uses for Stainless Steel fastenings as there are problems of corrosion, temperature and strength. Because of its high tensile strength, corrosion resistant qualities and ability to attain a mirror-like finish it is one of the most versatile of all metals. Applications include its use in the petroleum, chemical, food, plumbing, transportation and oil equipment industries to mention just a few. Listed on page 152 are the types of various Stainless Steel alloys which are most frequently used in the manufacture of fastenings.

CAP SCREWS

SAE STANDARD J429 - GRADES 2, 5 AND 8

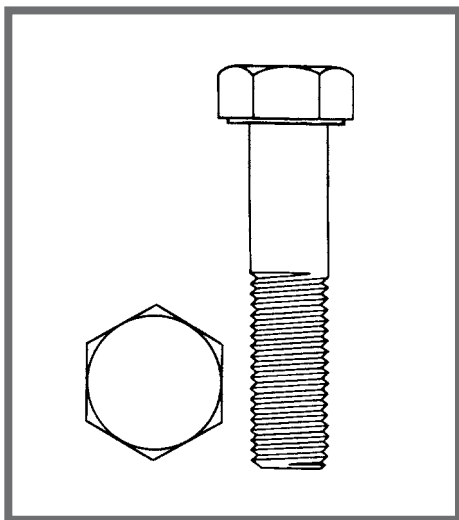
**GRADE 2**

Low-carbon bright $\frac{1}{4}$ in. to $1\frac{1}{2}$ in. inclusive, with minimum tensile strength of 74,000 psi in diameters through $\frac{3}{4}$ in. and 60,000 psi for diameters over $\frac{3}{4}$ in. through $1\frac{1}{2}$ in.

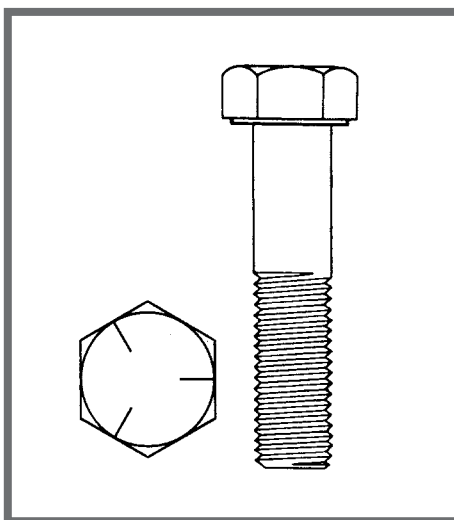
**GRADE 5**

Medium-carbon, heat treated in a carbon controlled atmosphere, $\frac{1}{4}$ in. to $1\frac{1}{2}$ in., inclusive, with minimum tensile strength of 120,000 psi in diameters through 1 in. and 105,000 psi for diameters over 1 in. through $1\frac{1}{2}$ in. Grade 5 will also meet other specifications such as ASTM A449.

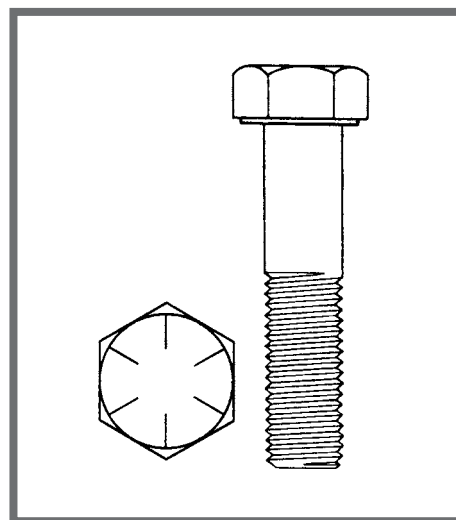
**GRADE 8**

Alloy, heat treated in a carbon controlled atmosphere, $\frac{1}{4}$ in. to 1 in., inclusive, with minimum tensile strength of 150,000 psi. Grade 8 will also meet ASTM specification A354 Grade BD.

NOTICE TO FINE THREAD USERS!

Grade 2 is not recommended for use with fine threads.

We suggest the use of Grade 5 or better because of superior resistance to stripping during tightening. Grade 2 may be used as an alternate for ASTM A307 Grade A.



K.L. Jack is a quality-focused distributor

supplying the finest fasteners and related supplies from respected manufacturers.

With an inventory of over 30 million pieces

we have what you need or we'll find it for you!







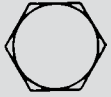

FASTENERS

MASONRY
ANCHORSDRILLS/SAWS
& ABRASIVESTOOLS &
ACCESSORIESCONTRACTOR
& INDUSTRIALSAFETY
PRODUCTSCHEMICALS
& JANITORIALAUTO &
ELECTRICALSTRUT &
HANGERS

IDENTIFICATION MARKINGS ON BOLT HEADS

ASTM AND SAE STANDARDS - SPECIFICATIONS - PROOF LOADS - TENSILE STRENGTHS

FASTENERS
**MASONRY
ANCHORS**
**DRILLS/SAWS
& ABRASIVES**
**TOOLS &
ACCESSORIES**
**CONTRACTOR
& INDUSTRIAL**
**SAFETY
PRODUCTS**
**CHEMICALS
& JANITORIAL**
**AUTO &
ELECTRICAL**
**STRUT &
HANGERS**

Grade Marking	Specification	Material	Bolt and Screw Size (Inches)	Proof Load psi	Tensile Strength min. psi
	SAE-J429 Grade 1	Low or Medium Carbon Steel	1/4 thru 1-1/2	33,000	60,000
	ASTM-A307		1/4 thru 4		60,000
	SAE-J429 Grade-2	Low or Medium Carbon Steel	1/4 thru 3/4 Over 3/4 thru 1-1/2	55,000 33,000	74,000 60,000
	SAE-J429 Grade 5	Medium Carbon Steel Quenched and Tempered	1/4 thru 1 Over 1 thru 1-1/4	85,000 74,000	120,000 105,000
	ASTM-A449		1/4 thru 1 Over 1 thru 1-1/2	85,000 74,000	120,000 105,000
			Over 1-1/2 thru 3	55,000	90,000
* 	ASTM-A325 Type 1	Medium Carbon Steel Quenched and Tempered	1/2 thru 1-1/2 Over 1 thru 1-1/2	85,000 74,000	120,000 105,000
	ASTM-A325 Type 3	Weather Resistant Steel Quenched and Tempered	1-1/8 thru 1-1/2 1/2 thru 1	74,000 85,000	105,000 120,000
	ASTM-A354 Grade BB	Low Alloy Steel Quenched and Tempered	1/4 thru 2-1/2 Over 2-1/4 thru 4	80,000 75,000	105,000 100,000
	ASTM-A354 Grade BC	Alloy Steel Quenched and Tempered	1/4 thru 4 Over 2-1/2 thru 4	105,000 95,000	125,000 115,000
	SAE-J429 GRADE 8	Medium Carbon Alloy Steel Quenched and Tempered	1/4 thru 1-1/2	120,000	150,000
	ASTM-A354 Grade BD	Alloy Steel Quenched and Tempered			
	ASTM-A490 Type 1	Alloy Steel Quenched and Tempered	1/2 thru 1-1/2	120,000	150,000

* Radial lines on Type 1 bolts are optional to manufacturer.
Bolt Head markings include manufacturers identity symbols.

CAP SCREWS - SAEJ429

PROOF LOAD AND TENSILE STRENGTH REQUIREMENTS

COARSE THREAD SERIES — UNC

Nominal Dia. Of Products And Threads Per Inch	Grade 2		Grade 5		Grade 8	
	Proof Load, Lb.	Tensile Strength Min., Lb.	Proof Load, Lb.	Tensile Strength Min., Lb.	Proof Load, Lb.	Tensile Strength Min., Lb.
1/4 - 20	1,750	2,350	2,700	3,800	3,800	4,750
5/16 - 18	2,900	3,900	4,450	6,300	6,300	7,850
3/8 - 16	4,250	5,750	6,600	9,300	9,300	11,600
7/16 - 14	5,850	7,850	9,050	12,800	12,800	15,900
1/2 - 13	7,800	10,500	12,100	17,000	17,000	21,300
9/16 - 12	10,000	13,500	15,500	21,800	21,800	27,300
5/8 - 11	12,400	16,700	19,200	27,100	27,100	33,900
3/4 - 10	18,400	24,700	28,400	40,100	40,100	50,100
7/8 - 9	15,200	27,700	39,300	55,400	55,400	69,300
1 - 8	20,000	36,400	51,500	72,700	72,700	90,900
1-1/8 - 7	25,200	45,800	56,500	80,100	91,600	114,400
1-1/4 - 7	32,000	58,100	71,700	101,700	116,300	145,400
1-3/8 - 6	38,100	69,300	85,500	121,300	138,600	173,200
1-1/2 - 6	46,400	84,300	104,000	147,500	168,600	210,800

FINE THREAD SERIES — UNF

Nominal Dia. Of Products And Threads Per Inch	Grade 2		Grade 5		Grade 8	
	Proof Load, Lb.	Tensile Strength Min., Lb.	Proof Load, Lb.	Tensile Strength Min., Lb.	Proof Load, Lb.	Tensile Strength Min., Lb.
1/4 - 28	2,000	2,700	3,100	4,350	4,350	5,450
5/16 - 24	3,200	4,300	4,900	6,950	6,950	8,700
3/8 - 24	4,800	6,500	7,450	10,500	10,500	13,200
7/16 - 20	6,550	8,800	10,100	14,200	14,200	17,800
1/2 - 20	8,800	11,800	13,600	19,200	19,200	24,000
9/16 - 18	11,200	15,000	17,300	24,400	24,400	30,400
5/8 - 18	14,100	18,900	21,800	30,700	30,700	38,400
3/4 - 16	20,500	27,600	31,700	44,800	44,800	56,000
7/8 - 14	16,800	30,500	43,300	61,100	61,100	76,400
1 - 12	21,900	39,800	56,400	79,600	79,600	99,400
1 - 14 uns	22,400	40,700	57,700	81,500	81,500	101,900
1 - 1/8 - 12	28,200	51,400	63,300	89,900	102,700	128,400
1 - 1/4 - 12	35,400	64,400	79,400	112,700	128,800	161,000
1 - 3/8 - 12	43,400	78,900	97,300	138,100	157,800	197,200
1 - 1/2 - 12	52,200	94,900	117,000	166,000	189,700	237,200

FASTENERS

MASONRY
ANCHORSDRILLS/SAWS
& ABRASIVESTOOLS &
ACCESSORIESCONTRACTOR
& INDUSTRIALSAFETY
PRODUCTSCHEMICALS
& JANITORIALAUTO &
ELECTRICALSTRUT &
HANGERS

HEX HEAD CAP SCREWS

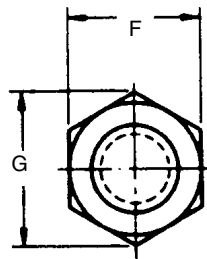
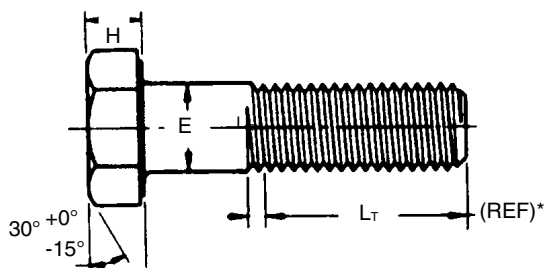

*BASIC THREAD LENGTH, L_T , is a reference dimension, intended for calculation purposes only, which represents the distance from the extreme end of the screw or bolt to the last complete (full form) thread.

Nominal Size Or Basic Screw Dia.	E		F			G		H			L _T (Ref.)*	
	Body Dia.		Width Across Flats			Width Across Corners		Height			Thread Lengths For Screw Length	
	Max.	Min.	Basic	Max.	Min.	Max.	Min.	Basic	Max.	Min.	≤6 in.	≥.6 in.
											Basic	Basic
1/4	0.2500	0.2450	7/16	0.438	0.428	0.505	0.488	5/32	0.163	0.150	0.750	1.000
5/16	0.3125	0.3065	1/2	0.500	0.489	0.577	0.557	13/64	0.211	0.195	0.875	1.125
3/8	0.3750	0.3690	9/16	0.562	0.551	0.650	0.628	15/64	0.243	0.226	1.000	1.250
7/16	0.4375	0.4305	5/8	0.625	0.612	0.722	0.698	9/32	0.291	0.272	1.125	1.375
1/2	0.5000	0.4930	3/4	0.750	0.736	0.866	0.840	5/16	0.323	0.302	1.250	1.500
9/16	0.5625	0.5545	13/16	0.812	0.798	0.938	0.910	23/64	0.371	0.348	1.375	1.625
5/8	0.6250	0.6170	15/16	0.938	0.922	1.083	1.051	25/64	0.403	0.378	1.500	1.750
3/4	0.7500	0.7410	1 1/8	1.125	1.100	1.299	1.254	15/32	0.483	0.455	1.750	2.000
7/8	0.8750	0.8660	1 5/16	1.312	1.285	1.516	1.465	35/64	0.563	0.531	2.000	2.250
1	1.0000	0.9900	1 1/2	1.500	1.469	1.732	1.675	39/64	0.627	0.591	2.250	2.500
1 1/8	1.1250	1.1140	1 11/16	1.688	1.631	1.949	1.859	11/16	0.718	0.658	2.500	2.750
1 1/4	1.2500	1.2390	1 7/8	1.875	1.812	2.165	2.066	25/32	0.813	0.749	2.750	3.000
1 3/8	1.3750	1.3630	2 1/16	2.062	1.994	2.382	2.273	27/32	0.878	0.810	3.000	3.250
1 1/2	1.5000	1.4880	2 1/4	2.250	2.175	2.598	2.480	15/16	0.974	0.902	3.250	3.500
1 3/4	1.7500	1.7380	2 5/8	2.625	2.538	3.031	2.893	1 3/32	1.134	1.054	3.750	4.000
2	2.0000	1.9880	3	3.000	2.900	3.464	3.306	1 7/32	1.263	1.175	4.250	4.500
2 1/4	2.2500	2.2380	3 3/8	3.375	3.262	3.897	3.719	1 3/8	1.423	1.327	4.750	5.000
2 1/2	2.5000	2.4880	3 3/4	3.750	3.625	4.330	4.133	1 17/32	1.583	1.479	5.250	5.500
2 3/4	2.7500	2.7380	4 1/8	4.125	3.988	4.763	4.546	1 11/16	1.744	1.632	5.750	6.000
3	3.0000	2.9880	4 1/2	4.500	4.350	5.196	4.959	1 7/8	1.935	1.815	6.250	6.500

Visit us on the web at www.kljack.com

A325 BOLTS, NUTS AND WASHERS

BOLT DIMENSIONS

Nominal Size of Basic Bolt Dia.	E		F			G		H			R		L _T (Ref)	Y (Ref)	Runout of Bearing Surface FIR
	Body Diameter		Width Across Flats			Width Across Corner		Height			Radius Of Fillet		Thread Length	Transition Thread Length	
	Max	Min	Basic	Max	Min	Max	Min	Basic	Max	Min	Max	Min			
1/2 0.5000	0.515	0.482	7/8	0.875	0.850	1.010	0.969	5/16	0.323	0.302	0.031	0.009	1.00	0.19	0.016
5/8 0.6250	0.642	0.605	1-1/16	1.062	1.031	1.227	1.175	25/64	0.403	0.378	0.062	0.021	1.25	0.22	0.019
3/4 0.7500	0.768	0.729	1-1/4	1.250	1.212	1.443	1.383	15/32	0.483	0.455	0.062	0.021	1.38	0.25	0.022
7/8 0.8750	0.895	0.852	1-7/16	1.438	1.394	1.660	1.589	35/64	0.563	0.531	0.062	0.031	1.50	0.28	0.025
1 1.0000	1.022	0.976	1-5/8	1.625	1.575	1.876	1.796	35/64	0.627	0.591	0.093	0.062	1.75	0.31	0.028
1-1/8 1.1250	1.149	1.098	1-13/16	1.812	1.756	2.093	2.002	11/16	0.718	0.658	0.093	0.062	2.00	0.34	0.032
1-1/4 1.2500	1.277	1.223	2	2.000	1.938	2.309	2.209	25/32	0.813	0.749	0.093	0.062	2.00	0.38	0.035
1-3/8 1.3750	1.404	1.345	2-3/16	2.188	2.119	2.526	2.416	27/32	0.878	0.810	0.093	0.062	2.25	0.44	0.038
1-1/2 1.5000	1.531	1.470	2-3/8	2.375	2.300	2.742	2.622	15/16	0.974	0.902	0.093	0.062	2.25	0.44	0.041

ASTM F436 WASHER DIMENSIONS

Bolt Size E	Circular Washers				Square or Rectangular Beveled Washers for American Standard Beams and Channels		
	Nominal Outside Diameter	Nominal Diameter of Hole	Thickness		Minimum Side Dimension	Mean Thickness	Slope or Taper in Thickness
			Min.	Max.			
1/2	1-1/16	17/32	0.097	0.177	1-3/4	5/16	1:6
5/8	1-5/16	11/16	0.122	0.177	1-3/4	5/16	1:6
3/4	1-15/32	13/16	0.122	0.177	1-3/4	5/16	1:6
7/8	1-3/4	15/16	0.136	0.177	1-3/4	5/16	1:6
1	2	1-1/8	0.136	0.177	1-3/4	5/16	1:6
1-1/8	2-1/4	1-1/4	0.136	0.177	2-1/4	5/16	1:6
1-1/4	2-1/2	1-3/8	0.136	0.177	2-1/4	5/16	1:6
1-3/8	2-3/4	1-1/2	0.136	0.177	2-1/4	5/16	1:6
1-1/2	3	1-5/8	0.136	0.177	2-1/4	5/16	1:6

WASHER DIMENSIONS TOLERANCES (INCHES)

Dimensions	Washer Size To 1-1/2 in. Nominal Bolt Size, incl.
Nominal diameter of hole	-0: + 1/32
Nominal outside dimensions	-1/32 + 1/4
Flatness: max. deviation from straight edge placed on "cut" side shall not exceed	0.01
Burr shall not project above immediately adjacent washer surface more than	0.01

A563 GrC/DH NUT DIMENSIONS

Nut Size in Inches	Inches	
	Heavy Hex Nuts	
	Width Across Flats F	Height G
1/2	7/8	31/64
5/8	1-1/16	39/64
3/4	1-1/4	47/64
7/8	1-7/16	55/64
1	1-5/8	63/64
1-1/8	1-13/16	1-7/64
1-1/4	2	1-7/32
1-3/8	2-3/16	1-11/32
1-1/2	2-3/8	1-15/32

NUTS - HEX AND HEAVY HEX

ASTM A563 - GRADE A

DIMENSIONS

Hex nuts are available in diameters ranging from 1/4 in. to 2 in. Double chamfered through the 1 in. size, and washer faced in sizes over 1 in. Heavy hex nuts are available from 1/4 in. to 4 in., washer faced in the full range of sizes, as well as double chamfered in sizes through 1 in.

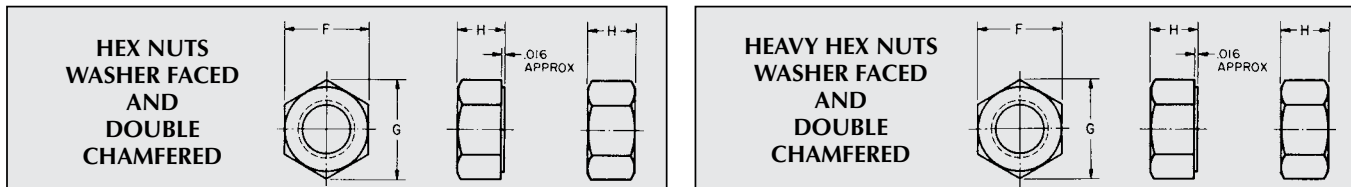

HEX NUTS DIMENSIONS (IN.) ANSI B18.22

Nominal Size or Basic Major Dia. of Thread	F - Width Across Flats			G - Width Across Corners		H - Thickness Finish Hex Nuts			
	Basic	Max.	Min.	Max.	Min.	Basic	Max.	Min.	
1/4	0.2500	7/16	0.438	0.428	0.505	0.488	7/32	0.226	0.212
5/16	0.3125	1/2	0.500	0.489	0.577	0.557	17/64	0.273	0.258
3/8	0.3750	9/16	0.562	0.551	0.650	0.628	21/64	0.337	0.320
7/16	0.4375	11/16	0.688	0.675	0.794	0.768	3/8	0.385	0.365
1/2	0.5000	3/4	0.750	0.736	0.866	0.840	7/16	0.448	0.427
9/16	0.5625	7/8	0.875	0.861	1.010	0.982	31/64	0.496	0.473
5/8	0.6250	15/16	0.938	0.922	1.083	1.051	35/64	0.559	0.535
3/4	0.7500	1 1/8	1.125	1.088	1.299	1.240	41/64	0.665	0.617
7/8	0.8750	1 5/16	1.312	1.269	1.516	1.447	3/4	0.776	0.724
1	1.0000	1 1/2	1.500	1.450	1.732	1.653	55/64	0.887	0.831
1 1/8	1.1250	1 11/16	1.688	1.631	1.949	1.859	31/32	0.999	0.939
1 1/4	1.2500	1 7/8	1.875	1.812	2.165	2.066	1 1/16	1.094	1.030
1 3/8	1.3750	2 1/16	2.062	1.994	2.382	2.273	1 11/64	1.206	1.138
1 1/2	1.5000	2 1/4	2.250	2.175	2.598	2.480	1 9/32	1.317	1.245
1 3/4	1.7500	2 5/8	2.625	2.538	3.031	2.883	1 1/2	1.540	1.460
2	2.0000	3	3.000	2.900	3.464	3.306	1 23/32	1.763	1.675

HEAVY HEX NUTS DIMENSIONS (IN.) ANSI B18.22

Nominal Size or Basic Major Dia. of Thread	F - Width Across Flats			G - Width Across Corners		H - Thickness Heavy Hex Nuts			
	Basic	Max.	Min.	Max.	Min.	Basic	Max.	Min.	
1/4	0.2500	1/2	0.500	0.488	0.577	0.556	15/64	0.250	0.218
5/16	0.3125	9/16	0.562	0.546	0.650	0.622	19/64	0.314	0.280
3/8	0.3750	11/16	0.688	0.669	0.794	0.763	23/64	0.377	0.341
7/16	0.4375	3/4	0.750	0.728	0.866	0.830	27/64	0.441	0.403
1/2	0.5000	7/8	0.875	0.850	1.010	0.969	31/64	0.504	0.464
9/16	0.5625	15/16	0.938	0.909	1.083	1.037	35/64	0.568	0.526
5/8	0.6250	1 1/16	1.062	1.031	1.227	1.175	39/64	0.631	0.587
3/4	0.7500	1 1/4	1.250	1.212	1.443	1.382	47/64	0.758	0.710
7/8	0.8750	1 7/16	1.438	1.394	1.660	1.589	55/64	0.885	0.833
1	1.0000	1 5/8	1.625	1.575	1.876	1.796	63/64	1.012	0.956
1 1/8	1.1250	1 13/16	1.812	1.756	2.093	2.002	1 7/64	1.139	1.079
1 1/4	1.2500	2	2.000	1.938	2.309	2.209	1 7/32	1.251	1.187
1 3/8	1.3750	2 3/16	2.188	2.119	2.526	2.416	1 11/32	1.378	1.310
1 1/2	1.5000	2 3/8	2.375	2.300	2.742	2.622	1 15/32	1.505	1.433
1 5/8	1.6250	2 9/16	2.562	2.481	2.959	2.828	1 19/32	1.632	1.556
1 3/4	1.7500	2 3/4	2.750	2.662	3.175	3.035	1 23/32	1.759	1.679
1 7/8	1.8750	2 15/16	2.938	2.844	3.392	3.242	1 27/32	1.886	1.802
2	2.0000	3 1/8	3.125	3.025	3.608	3.449	1 31/32	2.013	1.925
2 1/4	2.2500	3 1/2	3.500	3.388	4.041	3.862	2 13/64	2.251	2.155
2 1/2	2.5000	3 7/8	3.875	3.750	4.474	4.275	2 29/64	2.505	2.401
2 3/4	2.7500	4 1/4	4.250	4.112	4.907	4.688	2 45/64	2.759	2.647
3	3.0000	4 3/8	4.625	4.475	5.340	5.102	2 61/64	3.013	2.893
3 1/4	3.2500	5	5.000	4.838	5.774	5.515	3 3/16	3.252	3.124
3 1/2	3.5000	5 3/8	5.375	5.200	6.207	5.928	3 7/16	3.506	3.370
3 3/4	3.7500	5 3/4	5.750	5.562	6.640	6.341	3 11/16	3.760	3.616
4	4.0000	6 1/8	6.125	5.925	7.073	6.755	3 15/16	4.014	3.862

FASTENERS
MASONRY ANCHORS
DRILLS/SAWS & ABRASIVES
TOOLS & ACCESSORIES
CONTRACTOR & INDUSTRIAL
SAFETY PRODUCTS
CHEMICALS & JANITORIAL
AUTO & ELECTRICAL
STRUT & HANGERS

CARBON AND ALLOY STEEL NUTS FOR HIGH-PRESSURE AND HIGH-TEMPERATURE SERVICE

ASTM A194 - GRADE 2H, 4 AND 7

AN STANDARD B18.2.2

For high-temperature, high-pressure in combination with alloy studs and bolts. These nuts are tapped UNC-2B in sizes of 1 in. and under or 8UN-2B over 1 in.

ASTM A194 - GRADE 2H

Quenched nuts suitable for high-temperature and high-pressure conditions.

ASTM A194 - GRADES 4 AND 7

Heat-treated carbon-molybdenum and chromium molybdenum steel nuts suitable for severe temperature and pressure conditions.

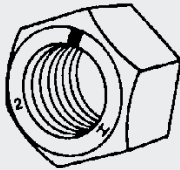

Grade 2H
ASTM A194

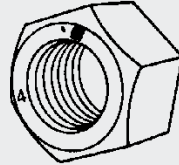

Grade 4
ASTM A194

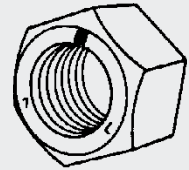

Grade 7
ASTM A194

Chemical Composition

Grade	C	Mn	P	S	Si	Mo	Cr
2H	0.40min	—	0.04 max	0.05 max	—	—	—
4	0.40 to 0.50	0.70 to 0.90	0.035 max	0.04 max	0.20 to 0.35	0.20 to 0.30	—
7	0.38 to 0.48	0.75 to 1.00	0.04 max	0.04 max	0.20 to 0.35	0.15 to 0.25	0.80 to 1.10

Hardness Requirements

Grade	Brinell	Rockwell B	Rockwell C
2H	248 to 352	—	24 to 38
4 and 7	248 to 352	—	24 to 38



Value Added Services

- Large Inventories • Servicing The Sale
- Standing For Quality • Saving You Money
- Solving Application Problems

FASTENERS
MASONRY ANCHORS
DRILLS/SAWS & ABRASIVES
TOOLS & ACCESSORIES
CONTRACTOR & INDUSTRIAL
SAFETY PRODUCTS
CHEMICALS & JANITORIAL
AUTO & ELECTRICAL
STRUT & HANGERS

FLAT WASHERS

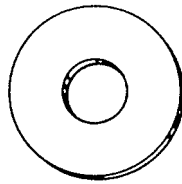

U.S. STANDARD (USS)

Developed to satisfy engineering requirements in the majority of industrial application in all fields of manufacturing, maintenance and repair. The O.D., I.D. and thickness specifications were developed to meet the optimum of applications.

All listed sizes are available in plain and zinc plated.

Bolt Size In.	Outside Diameter In.	Inside Diameter In.	Thickness
3/16	9/16	1/4	.036/.065
1/4	3/4	5/16	.051/.080
5/16	7/8	3/8	.064/.104
3/8	1	7/16	.064/.104
7/16	1 1/4	1/2	.064/.104
1/2	1 3/8	9/16	.086/.132
9/16	1 1/2	5/8	.086/.132
5/8	1 3/4	11/16	.108/.160
3/4	2	13/16	.122/.177
7/8	2 1/4	15/16	.136/.192
1	2 1/2	1 1/16	.136/.192
1 1/8	2 3/4	1 1/4	.136/.192
1 1/4	3	1 3/8	.136/.192
1 3/8	3 1/4	1 1/2	.153/.213
1 1/2	3 1/2	1 5/8	.153/.213
1 5/8	3 3/4	1 3/4	.153/.213
1 3/4	4	1 7/8	.153/.213
1 7/8	4 1/4	2	.153/.213
2	4 1/2	2 1/8	.153/.213
2 1/4	4 3/4	2 3/8	.193/.248
2 1/2	5	2 5/8	.210/.280
2 3/4	5 1/4	2 7/8	.228/.310
3	5 1/2	3 1/8	.249/.327

S.A.E.

Specifications for S.A.E. washers were developed and specified by the Society of Automotive Engineers to meet the requirements in most of the applications in its field. They are smaller O.D. and thinner gauges than their counterpart bolt sizes of U.S. Standard washers.

Bolt Size In.	Outside Diameter In.	Inside Diameter In.	Thickness
#6	3/8	5/32	.036/.065
#8	7/16	3/16	.036/.065
#10	1/2	7/32	.036/.065
#12	9/16	1/4	.051/.080
1/4	5/8	9/32	.051/.080
5/16	11/16	11/32	.051/.080
3/8	13/16	13/32	.051/.080
7/16	59/64	15/32	.051/.080
1/2	1 1/16	17/32	.074/.121
9/16	1 3/16	19/32	.074/.121
5/8	1 5/16	21/32	.074/.121
3/4	1 1/2	13/16	.108/.160
7/8	1 3/4	15/16	.108/.160
1	2	1 1/16	.108/.160
1 1/8	2 1/4	1 3/16	.108/.160
1 1/4	2 1/2	1 5/16	.136/.192
1 3/8	2 3/4	1 7/16	.136/.192
1 1/2	3	1 9/16	.153/.213

ANSI specifications allow a tolerance of plus or minus a gauge on nominal thickness of commercial washers.

SPLIT LOCKWASHERS

MEDIUM SPLIT HELICAL SPRING LOCKWASHERS

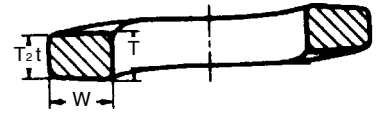

Nominal Washer Size	A Inside Diameter		B Outside Diameter	W Washer Section Width	T ² t - 2 Thickness
	Min.	Max.	Max. ²	Min.	Min.
2 0.086	0.088	0.094	0.172	0.035	0.020
4 0.112	0.115	0.121	0.209	0.040	0.025
5 0.125	0.128	0.134	0.236	0.047	0.031
6 0.138	0.041	0.148	0.250	0.047	0.031
8 0.164	0.168	0.175	0.293	0.055	0.040
10 0.190	0.194	0.202	0.334	0.062	0.047
12 0.216	0.221	0.229	0.377	0.070	0.056
1/4 0.250	0.255	0.263	0.489	0.109	0.062
5/16 0.312	0.318	0.328	0.586	0.125	0.078
3/8 0.375	0.382	0.393	0.683	0.141	0.094
7/16 0.438	0.446	0.459	0.779	0.156	0.109
1/2 0.500	0.509	0.523	0.873	0.171	0.125
9/16 0.562	0.572	0.587	0.971	0.188	0.141
5/8 0.625	0.636	0.653	1.079	0.203	0.156
3/4 0.750	0.763	0.783	1.271	0.234	0.188
7/8 0.875	0.890	0.912	1.464	0.266	0.219
1 1.000	1.017	1.042	1.661	0.297	0.250
1 1/16 1.062	1.080	1.107	1.756	0.312	0.266
1 1/8 1.125	1.144	1.172	1.853	0.328	0.281
1 3/16 1.188	1.208	1.237	1.950	0.344	0.297
1 1/4 1.250	1.271	1.302	2.045	0.359	0.312
1 1/2 1.500	1.525	1.561	2.430	0.422	0.375

LOCKWASHERS

HI-COLLAR HELICAL SPRING

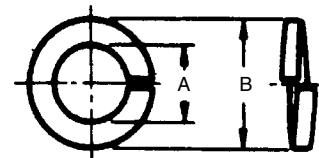

Nominal Washer Size	A Inside Diameter		B Outside Diameter	W Washer Section Width	T ² t - 2 Thickness
	Min.	Max.	Max. ²	Min.	Min.
4 0.112	0.115	0.121	0.173	0.022	0.022
6 0.138	0.141	0.148	0.216	0.030	0.030
8 0.164	0.168	0.175	0.267	0.042	0.047
10 0.190	0.194	0.202	0.294	0.042	0.047
1/4 0.250	0.255	0.263	0.365	0.047	0.078
5/16 0.312	0.318	0.328	0.460	0.062	0.093
3/8 0.375	0.382	0.393	0.553	0.076	0.125

INTERNAL TOOTH LOCKWASHERS

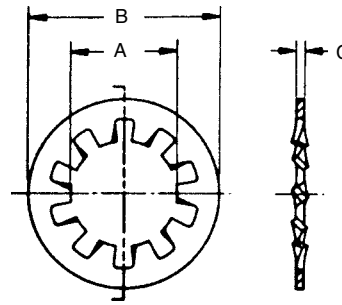

Nominal Washer Size	A Inside Diameter		B Outside Diameter		C Thickness	
	Min.	Max.	Max.	Min.	Max.	Min.
2 0.086	0.089	0.095	0.200	0.175	0.015	0.010
4 0.112	0.115	0.123	0.270	0.255	0.019	0.015
6 0.138	0.141	0.150	0.295	0.275	0.021	0.017
8 0.164	0.168	0.176	0.340	0.325	0.023	0.018
10 0.190	0.195	0.204	0.381	0.365	0.025	0.020
12 0.216	0.221	0.231	0.410	0.394	0.025	0.020
¹ / ₄ 0.250	0.256	0.267	0.478	0.460	0.028	0.023
⁵ / ₁₆ 0.312	0.320	0.332	0.610	0.594	0.034	0.028
³ / ₈ 0.375	0.384	0.398	0.692	0.670	0.040	0.032
⁷ / ₁₆ 0.438	0.448	0.464	0.789	0.740	0.040	0.032
¹ / ₂ 0.500	0.512	0.530	0.900	0.867	0.045	0.037
⁵ / ₈ 0.625	0.640	0.663	1.071	1.045	0.050	0.042

EXTERNAL TOOTH LOCKWASHERS

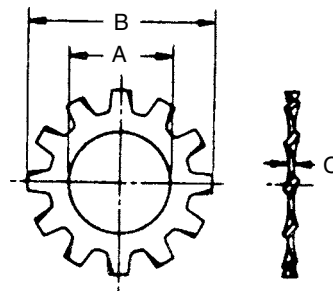

Nominal Washer Size	A Inside Diameter		B Outside Diameter		C Thickness	
	Min.	Max.	Max.	Min.	Max.	Min.
4 0.112	0.115	0.123	0.260	0.245	0.019	0.015
6 0.138	0.141	0.150	0.320	0.305	0.022	0.016
8 0.164	0.168	0.176	0.381	0.365	0.023	0.018
10 0.190	0.195	0.204	0.410	0.395	0.025	0.020
12 0.216	0.221	0.231	0.475	0.460	0.028	0.023
¹ / ₄ 0.250	0.256	0.267	0.510	0.494	0.028	0.023
⁵ / ₁₆ 0.312	0.320	0.332	0.610	0.588	0.034	0.028
³ / ₈ 0.375	0.384	0.398	0.694	0.670	0.040	0.032
⁷ / ₁₆ 0.438	0.448	0.464	0.760	0.740	0.040	0.032
¹ / ₂ 0.500	0.513	0.530	0.900	0.880	0.045	0.037
⁵ / ₈ 0.625	0.641	0.663	1.070	1.045	0.050	0.042

HEAT-TREATED ALLOY STUDS, BOLTS AND THREADED BARS

CHEMICAL COMPOSITION, HEAT-TREATED, ALLOY STEEL STUDS

Elements	A354 Grades BC, BD		A193 Grade B7	
	+ See note below		Chromium Molybdenum (AISI 4140, 4142, 4145)	
	Range percent	Check variation over percent	Range percent	Check variation Over or under percent
Carbon	—	—	•0.38-0.48	0.02
Manganese	—	—	0.75-1.00	0.04
Phosphorus, max	0.04	0.005	0.04	0.005 over
Sulphur, max	0.04	0.005	0.04	0.005 over
Silicon	—	—	0.20-0.35	0.02
Chromium	—	—	0.80-1.10	0.05
Molybdenum	—	—	0.15-0.25	0.02

Elements	A193 Grade B16, Chromium, Molybdenum, Vanadium	
	Range percent	Check variation Over or under percent
Carbon	0.36-0.44	0.02
Manganese	0.45-0.70	0.03
Phosphorus, max	0.04	0.005 over
Sulphur, max	0.04	0.005 over
Silicon	0.20-0.35	0.02
Chromium	0.80-1.15	0.05
Molybdenum	0.50-0.65	0.03
Vanadium	0.25-0.35	0.03

Elements	A320 Grade L7 Chromium-Molybdenum (AISI 4140, 4142, 4145)		A320 Grade L43 Nickel-Chromium Molybdenum (AISI 4340)	
	Range percent	Check variation over or under percent	Range percent	Check variation Over or under percent
Carbon	•0.38-0.48	0.02	0.38-0.43	0.02
Manganese	0.75-1.00	0.04	0.60-0.85	0.03
Phosphorus, max	0.04	0.005 over	0.04	0.005 over
Sulphur, max	0.04	0.005 over	0.04	0.005 over
Silicon	0.20-0.35	0.02	0.20-0.35	0.02
Nickel	—	—	1.65-2.00	0.05
Chromium	0.80-1.10	0.05	0.70-0.90	0.03
Molybdenum	0.15-0.25	0.02	0.20-0.30	0.02

• For bar sizes over 3-1/2 in. to 4 in., inclusive, the carbon content may be 0.50 pct max
+ Any alloy steel capable of meeting the tensile requirements of Specification A354 may be used

TENSILE REQUIREMENTS, HEAT-TREATED, ALLOY STEEL STUDS

Grade	Diameter, in.	Min. tempering temp F	Tensile strength min psi	Yield point min psi	Elongation in 2 in. min pct	Reduction of area min pct
A354 Grade BC	2-1/2 and under	850	125,000	109,000	16	50
	Over 2-1/2 to 4 incl	850	115,000	99,000	16	45
A354 Grade BD	1-1/2 and under	850	150,000	125,000	14	35
A193 Grade B7 Chromium Molybdenum	2-1/2 and under	1100	125,000	105,000	16	50
	Over 2-1/2 to 4 incl	1100	115,000	95,000	16	50
	Over 4 to 7 incl	1100	100,000	75,000	18	50
A193 Grade B16 Chromium Molybdenum Vanadium	2-1/2 and under	1200	125,000	105,000	18	50
	Over 2-1/2 to 4 incl	1200	110,000	95,000	17	45
	Over 4 to 7 incl	1200	100,000	85,000	16	45
A320 Grade L7 Chromium Molybdenum	2-1/2 and under	—	125,000	105,000	16	50
A320 Grade L43 Nickel Chromium Molybdenum	4 and under	—	125,000	105,000	16	50

Commonly used are the following grades of heat-treated alloy steel for high-pressure or extreme temperature service in diameters of 1/2 in. to 2 in., inclusive. Other grades and other diameters are available on special order.

ASTM A354 - Grades BC and BD

Heat treated alloy steels for applications at normal atmospheric temperatures where high strength is required.

ASTM A193 - Grade B7

A heat treated chromium-molybdenum steel widely used for medium high-temperature service.

ASTM A193 - Grade B16

A heat treated chromium-molybdenum-vanadium steel widely used for high-temperature service.

ASTM A320 - Grade L7

This grade is intended for low-temperature service down to minus 150° F and has a minimum Charpy impact value of 15 ft-lb at this temperature. Sizes 2-1/2 in. and under.

ASTM A320 - Grade L43

The same properties offered by Grade L7 in sizes up to 2-1/2 in. are obtainable up to 4 in. in Grade L43.

Heat-treated alloy steel bolts and threaded bars are also available in the grades listed above.

Bolts in diameters of 3/8 in. to 1-1/4 in., inclusive; bars in diameters of 1/2 in. to 2 in., inclusive.

These are available only on special order.

ANCHOR BOLTS

ASTM F1554

GRADE 36, 55, 105

(Mechanical Properties)

The ASTM F1554 specification was introduced in 1994 and covers anchor bolts designed to anchor structural supports to concrete foundations. F1554 anchor bolts can take the form of either headed bolts, straight rods, or bent anchor bolts. The three grades 36, 55 and 105 designate the minimum yield strength (ksi) of the anchor bolt. The bolts can either be cut or roll threaded and a weldable grade 55 can be substituted for grade 36 at the supplier's option. Color coding on the end 36 blue, 55 yellow and 105 red - helps facilitate easy identification in the field. Permanent manufacturer and grade marking is allowed under the supplementary requirements.

Grade	Size	Tensile, ksi	Yield, ksi, min	Yield, MPa, min	Elong % min	RA % min	Size	Nuts		Washers
								Plain	Galv	
36	1/4 - 4	58-80	36	248	23	40	1/4 - 1-1/2	A563A HEX	A563A HEX	F436
							1-5/8 - 4	A563A HEAVY HEX	A563A HEAVY HEX	F436
55	1/4 - 2	75-95	55	380	21	30	1/4 - 1-1/2	A563A HEAVY HEX	A563A HEAVY HEX	F436
	2-1/8 - 2-1/2	75-95	55	380	21	22				
	2-5/8 - 3	75-95	55	380	21	20	1-5/8 - 4	A563A HEAVY HEX	A563A HEAVY HEX	F436
	3-1/8 - 4	75-95	55	380	21	18				
105	1/4 - 3	125-150	105	724	15	45	1/4 - 1-1/2	A563DH HEX	A563DH HEAVY HEX	F436
							1-5/8 - 3	A563DH HEAVY HEX	A563DH HEAVY HEX	F436

HEX HEAD LAG SCREWS

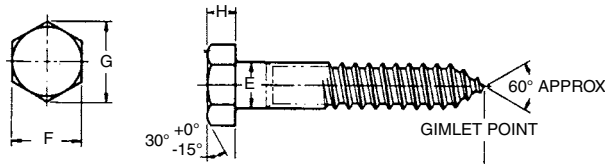

Nominal Size Or Basic Product Dia.	E		F			G		H			Threads Per Inch
	Body Or Shoulder Diameter		Width Across Flats			Width Across Corners		Height			
	Max.	Max.	Basic	Max.	Min.	Max.	Min.	Basic	Max.	Min.	
No.10	0.199	0.178	9/32	0.281	0.271	0.323	0.309	1/8	0.140	0.110	11
1/4	0.260	0.237	3/8	0.375	0.362	-	-	-	-	-	10
1/4	0.260	0.237	7/16	0.438	0.425	0.505	0.484	11/64	0.188	0.150	10
5/16	0.324	0.298	1/2	0.500	0.484	0.577	0.552	7/32	0.235	0.195	9
3/8	0.388	0.360	9/16	0.562	0.544	0.650	0.620	1/4	0.268	0.226	7
7/16	0.452	0.421	5/8	0.625	0.603	0.722	0.687	19/64	0.316	0.272	7
1/2	0.515	0.482	3/4	0.750	0.725	0.866	0.826	11/32	0.364	0.302	6
5/8	0.642	0.605	15/16	0.938	0.906	1.083	1.033	27/64	0.444	0.378	5
3/4	0.768	0.729	1 1/8	1.125	1.088	1.299	1.240	1/2	0.524	0.455	4 1/2
7/8	0.895	0.852	1 15/16	1.312	1.269	1.516	1.447	37/64	0.604	0.531	4
1	1.022	0.976	1 1/2	1.500	1.450	1.732	1.653	43/64	0.700	0.591	3 1/2
1 1/8	1.149	1.098	1 11/16	1.688	1.631	1.949	1.859	3/4	0.780	0.658	3 1/4
1 1/4	1.277	1.223	1 7/8	1.875	1.812	2.165	2.066	27/32	0.876	0.749	3 1/4

CARRIAGE BOLTS

ASTM A307 Grade A - (Mechanical Properties)

MINIMUM THREAD LENGTH

The formula for determining thread length is, Bolts 6 in. and shorter, 2 diameters plus 1/4 in. Bolts over 6 in. 2 diameters plus 1/2 in. If bolts are too short to apply the formula, the thread will be extended as close to head as possible.

SQUARE-NECK CARRIAGE BOLT DIMENSIONS (in.) ANSI B18.5

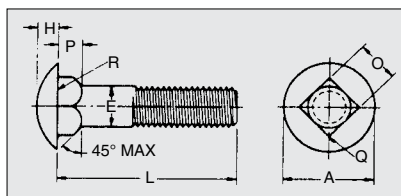

Nominal Size or Basic Bolt Diameter	Body Diameter		Head Diameter		Head Height		Square Width		Square Depth		Corner Radius on Square	Fillet Radius	
	Max.	Min.	Max.	Min.	Max.	Min.	Max.	Min.	Max.	Min.	Max.	Max.	
3/16	0.1900	0.199	0.182	0.469	0.438	0.114	0.094	0.199	0.185	0.125	0.094	0.031	0.031
1/4	0.2500	0.260	0.237	0.594	0.563	0.145	0.125	0.260	0.245	0.156	0.125	0.031	0.031
5/16	0.3125	0.324	0.298	0.719	0.688	0.176	0.156	0.324	0.307	0.187	0.156	0.031	0.031
3/8	0.3750	0.388	0.360	0.844	0.782	0.208	0.188	0.388	0.368	0.219	0.188	0.047	0.031
7/16	0.4375	0.452	0.421	0.969	0.907	0.239	0.219	0.452	0.431	0.250	0.219	0.047	0.031
1/2	0.5000	0.515	0.483	1.094	1.032	0.270	0.250	0.515	0.492	0.281	0.250	0.047	0.031
5/8	0.6250	0.642	0.605	1.344	1.219	0.344	0.313	0.642	0.616	0.344	0.313	0.078	0.062
3/4	0.7500	0.768	0.729	1.594	1.469	0.406	0.375	0.768	0.741	0.406	0.375	0.078	0.062

Full size body bolts are furnished unless user specifies undersize body bolts

STEP BOLTS

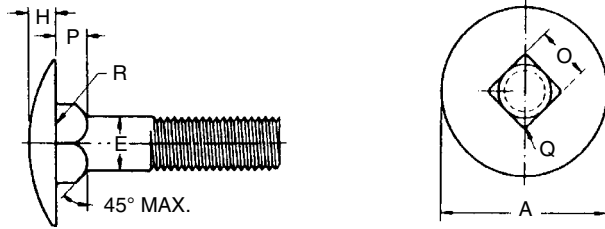

Nominal Size ¹ or Basic Bolt Diameter	E		A		H		O		P		Q	R
	Body Diameter		Head Diameter		Head Height		Square Width		Square Depth		Corner Radius on Square	Fillet Radius
	Max.	Min.	Max.	Min.	Max.	Min.	Max.	Min.	Max.	Min.	Max.	Max.
No.10	0.199	0.182	0.656	0.625	0.114	0.094	0.199	0.185	0.125	0.094	0.031	0.031
1/4	0.260	0.237	0.844	0.813	0.145	0.125	0.260	0.245	0.156	0.125	0.031	0.031
5/16	0.324	0.298	1.031	1.000	0.176	0.156	0.324	0.307	0.187	0.156	0.031	0.031
3/8	0.388	0.360	1.249	1.188	0.208	0.188	0.388	0.368	0.219	0.188	0.047	0.031
7/16	0.452	0.421	1.406	1.375	0.239	0.219	0.452	0.431	0.250	0.219	0.047	0.031
1/2	0.515	0.483	1.594	1.563	0.270	0.250	0.515	0.492	0.281	0.250	0.047	0.031

NOTES: 1. Where specifying nominal size in decimals, zeros preceding decimal and in the fourth decimal place shall be omitted.

ELEVATOR BOLTS

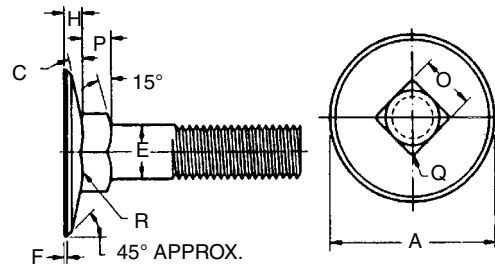

Nominal Size ¹ or Basic Bolt Diameter	E		A			C	F	H		O		P		Q	R
	Body Diameter		Head Diameter			Head Angle	Flat on Min. Dia. Head	Head Height		Square Width		Square Depth		Corner Radius on Square	Fillet Radius
	Max.	Min.	Max. Edge Sharp	Min. Edge Sharp	Min. Edge Flat			Ref.	Max.	Max.	Min.	Max.	Min.		
No.10	0.199	0.182	0.790	0.750	0.740	9°	0.025	0.082	0.062	0.210	0.185	0.125	0.094	0.031	0.031
1/4	0.260	0.237	1.008	0.969	0.938	9°	0.035	0.098	0.078	0.280	0.245	0.219	0.188	0.031	0.031
5/16	0.324	0.298	1.227	1.188	1.157	9°	0.035	0.114	0.094	0.342	0.307	0.250	0.219	0.031	0.031
3/8	0.388	0.360	1.352	1.312	1.272	11°	0.040	0.145	0.125	0.405	0.368	0.250	0.219	0.047	0.031
7/16	0.452	0.421	1.477	1.438	1.397	13°	0.040	0.176	0.156	0.468	0.431	0.281	0.250	0.047	0.031
1/2	0.515	0.483	1.602	1.562	1.532	12°	0.040	0.176	0.156	0.530	0.492	0.281	0.250	0.047	0.031

NOTES: 1. Where specifying nominal size in decimals, zeros preceding decimal and in the fourth decimal place shall be omitted.

NO. 3 HEAD PLOW BOLTS

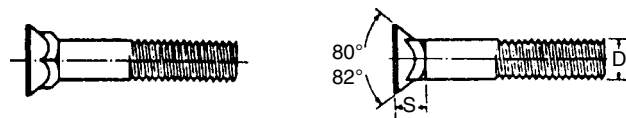

D	A			F	S		B	
Nominal Diameter of Bolt	Diameter of Head			Feed Thickness	Depth of Square and Head		Width of Square	
	Max.	Min. Sharp	Abs. Min. With Flat	Max.	Max.	Min.	Max.	Min. (Basic)
3/8	0.708	0.671	0.656	0.031	0.312	0.281	0.387	0.375
7/16	0.826	0.781	0.766	0.036	0.364	0.328	0.450	0.438
1/2	0.945	0.890	0.875	0.042	0.417	0.375	0.515	0.500
5/8	1.147	1.094	1.063	0.050	0.506	0.456	0.640	0.625

HEX SOCKET HEAD CAP SCREWS

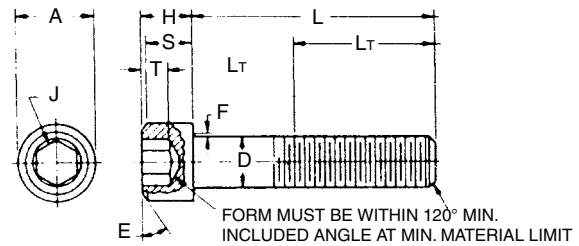

Nominal Size or Basic Screw Diameter	D Body Diameter		A Head Diameter		H Head Height		S Head Side Height	J Hexagon Socket Size	T Key Engage- ment	F Fillet Extension Above D		L _T Thread Length	
	Max.	Min.	Max.	Min.	Max.	Min.	Min.	Nom.	Min.	Max.	Min.	Min.	
0	0.0600	0.0600	0.0568	0.096	0.091	0.060	0.057	0.054	0.050	0.025	0.007	0.003	0.50
1	0.0730	0.0730	0.0695	0.118	0.112	0.073	0.070	0.066	1/16 0.062	0.031	0.007	0.003	0.62
2	0.0860	0.0860	0.0822	0.140	0.134	0.086	0.083	0.077	5/64 0.078	0.038	0.008	0.004	0.62
3	0.0990	0.0990	0.0949	0.161	0.154	0.099	0.095	0.089	5/64 0.078	0.044	0.008	0.004	0.62
4	0.1120	0.1120	0.1075	0.183	0.176	0.112	0.108	0.101	3/32 0.094	0.051	0.009	0.005	0.75
5	0.1250	0.1250	0.1202	0.205	0.198	0.125	0.121	0.112	3/32 0.094	0.057	0.010	0.006	0.75
6	0.1380	0.1380	0.1329	0.226	0.218	0.138	0.134	0.124	7/64 0.109	0.064	0.010	0.006	0.75
8	0.1640	0.1640	0.1585	0.270	0.262	0.164	0.159	0.148	9/64 0.141	0.077	0.012	0.007	0.88
10	0.1900	0.1900	0.1840	0.312	0.303	0.190	0.185	0.171	5/32 0.156	0.090	0.014	0.009	0.88
1/4	0.2500	0.2500	0.2435	0.375	0.365	0.250	0.244	0.225	3/16 0.188	0.120	0.014	0.009	1.00
5/16	0.3125	0.3125	0.3053	0.469	0.457	0.312	0.306	0.281	1/4 0.250	0.151	0.017	0.012	1.12
3/8	0.3750	0.3750	0.3678	0.562	0.550	0.375	0.368	0.337	5/16 0.312	0.182	0.020	0.015	1.25
7/16	0.4375	0.4375	0.4294	0.656	0.642	0.438	0.430	0.394	3/8 0.375	0.213	0.023	0.018	1.38
1/2	0.5000	0.5000	0.4919	0.750	0.735	0.500	0.492	0.450	3/8 0.375	0.245	0.026	0.020	1.50
5/8	0.6250	0.6250	0.6163	0.938	0.921	0.625	0.616	0.562	1/2 0.500	0.307	0.032	0.024	1.75
3/4	0.7500	0.7500	0.7406	1.125	1.107	0.750	0.740	0.675	5/8 0.625	0.370	0.039	0.030	2.00
7/8	0.8750	0.8750	0.8647	1.312	1.293	0.875	0.864	0.787	3/4 0.750	0.432	0.044	0.034	2.25
1	1.0000	1.0000	0.9886	1.500	1.479	1.000	0.988	0.900	3/4 0.750	0.495	0.050	0.040	2.50
1 1/4	1.2500	1.2500	1.2336	1.875	1.852	1.250	1.236	1.125	7/8 0.875	0.620	0.060	0.050	3.12
1 1/2	1.5000	1.5000	1.4818	2.250	2.224	1.500	1.485	1.350	1 1.000	0.745	0.070	0.060	3.75

HEX SOCKET BUTTON HEAD SCREWS

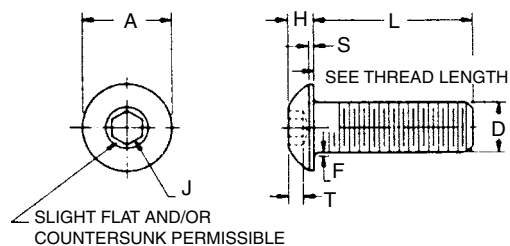

Nominal Size or Basic Screw Diameter	D Head Diameter		H Head Height		S Head Side Height	J Hexagon Socket Size	T Key Engage- ment	F Fillet Extension Above D		L Maximum Standard Length	
	Max.	Min.	Max.	Min.	Ref.	Nom.	Min.	Max.	Min.	Nom.	
2	0.0860	0.164	0.154	0.046	0.038	0.010	0.050	0.028	0.010	0.005	1/2
3	0.0990	0.188	0.176	0.052	0.044	0.010	1/16 0.062	0.035	0.010	0.005	1/2
4	0.1120	0.213	0.201	0.059	0.051	0.015	1/16 0.062	0.035	0.010	0.005	1/2
5	0.1250	0.238	0.226	0.066	0.058	0.015	5/64 0.078	0.044	0.010	0.005	1/2
6	0.1380	0.262	0.250	0.073	0.063	0.015	5/64 0.078	0.044	0.010	0.005	5/8
8	0.1640	0.312	0.298	0.087	0.077	0.015	3/32 0.094	0.052	0.015	0.010	3/4
10	0.1900	0.361	0.347	0.101	0.091	0.020	1/8 0.125	0.070	0.015	0.010	1
1/4	0.2500	0.437	0.419	0.132	0.122	0.031	5/32 0.156	0.087	0.020	0.015	1
5/16	0.3125	0.547	0.527	0.166	0.152	0.031	3/16 0.188	0.105	0.020	0.015	1
3/8	0.3750	0.656	0.636	0.199	0.185	0.031	7/32 0.219	0.122	0.020	0.015	1 1/4
1/2	0.5000	0.875	0.851	0.265	0.245	0.046	5/16 0.312	0.175	0.030	0.020	2
5/8	0.6250	1.000	0.970	0.331	0.311	0.062	3/8 0.375	0.210	0.030	0.020	2

FASTENERS
MASONRY ANCHORS
DRILLS/SAWS & ABRASIVES
TOOLS & ACCESSORIES
CONTRACTOR & INDUSTRIAL
SAFETY PRODUCTS
CHEMICALS & JANITORIAL
AUTO & ELECTRICAL
STRUT & HANGERS

FASTENERS
MASONRY ANCHORS
DRILLS/SAWS & ABRASIVES
TOOLS & ACCESSORIES
CONTRACTOR & INDUSTRIAL
SAFETY PRODUCTS
CHEMICALS & JANITORIAL
AUTO & ELECTRICAL
STRUT & HANGERS

HEX SOCKET SHOULDER SCREWS

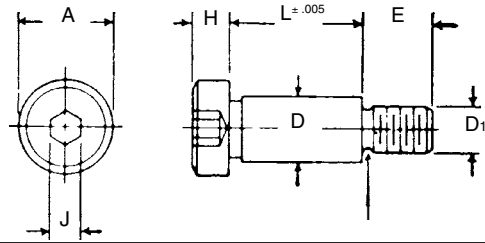

Nominal Size or Basic Shoulder Diameter	D		A		H		D		Threads Per Inch	E	I	J		
	Shoulder Diameter		Head Diameter		Head Height		Nominal Thread Size or Basic Thread Diameter						Thread Length Basic	Thread Neck Width Max.
	Max.	Min.	Max.	Min.	Max.	Min.								
1/4	0.250	0.2480	0.2460	0.375	0.357	0.188	0.177	10	0.1900	24	0.375	0.062	1/8	0.125
5/16	0.312	0.3105	0.3085	0.438	0.419	0.219	0.209	1/4	0.2500	20	0.438	0.075	5/32	0.156
3/8	0.375	0.3730	0.3710	0.562	0.543	0.250	0.240	5/16	0.3125	18	0.500	0.083	3/16	0.188
1/2	0.500	0.4980	0.4960	0.750	0.729	0.312	0.302	3/8	0.3750	16	0.625	0.093	1/4	0.250
5/8	0.625	0.6230	0.6210	0.875	0.853	0.375	0.365	1/2	0.5000	13	0.750	0.115	5/16	0.312
3/4	0.750	0.7480	0.7460	1.000	0.977	0.500	0.490	5/8	0.6250	11	0.875	0.136	3/8	0.375
1	1.000	0.9980	0.9960	1.312	1.287	0.625	0.610	3/4	0.7500	10	1.000	0.150	1/2	0.500

HEX SOCKET SET SCREWS

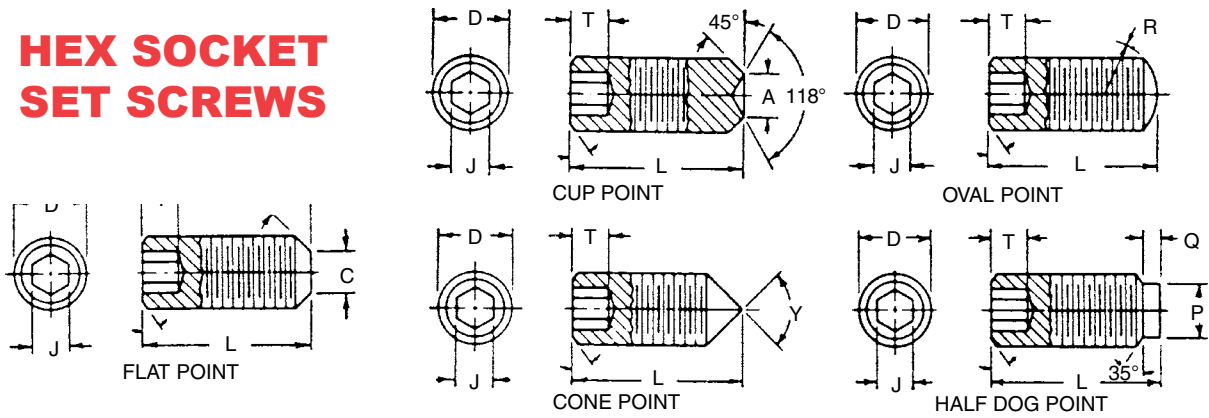

Nominal Diameter	D		A	R	Y	P		Q	J	T	Shortest Length to which Column T Applies
	Cup and Flat Point Diameter		Oval Point Radius	Cone Point Angle 90±2 for these Lengths and Over	Half Dog Point ¹		Length Nom.	Socket Width Across Flats Nom.	Key Engagement Min.		
	Max.	Min.			Max.	Min.					
0	0.033	0.027	0.045	5/64	0.040	0.037	0.015	0.028	0.050	7/64	
1	0.040	0.033	0.055	3/32	0.049	0.045	0.019	0.035	0.060	1/8	
2	0.047	0.039	0.064	7/64	0.057	0.053	0.022	0.035	0.060	1/8	
3	0.054	0.045	0.074	1/8	0.066	0.062	0.025	0.050	0.070	9/64	
4	0.061	0.051	0.084	5/32	0.075	0.070	0.028	0.050	0.070	9/64	
5	0.067	0.057	0.094	3/16	0.083	0.078	0.030	1/16	0.080	3/16	
6	0.074	0.064	0.104	3/16	0.092	0.087	0.035	1/16	0.080	11/64	
8	0.087	0.076	0.123	1/4	0.109	0.103	0.040	5/64	0.090	3/16	
10	0.102	0.088	0.142	1/4	0.127	0.120	0.045	3/32	0.100	3/16	
1/4	0.132	0.118	0.188	5/16	5/32	0.149	1/16	1/8	0.125	1/4	
5/16	0.172	0.156	0.234	3/8	13/64	0.195	5/64	5/32	0.156	5/16	
3/8	0.212	0.194	0.281	7/16	1/4	0.241	3/32	3/16	0.188	3/8	
7/16	0.252	0.232	0.328	1/2	19/64	0.287	7/64	7/32	0.219	7/16	
1/2	0.291	0.270	0.375	9/16	11/32	0.334	1/8	1/4	0.250	1/2	
5/8	0.371	0.347	0.469	3/4	15/32	0.456	5/32	5/16	0.312	5/8	
3/4	0.450	0.425	0.562	7/8	9/16	0.549	3/16	3/8	0.375	3/4	
7/8	0.530	0.502	0.656	1	21/32	0.642	7/32	1/2	0.500	7/8	
1	0.609	0.579	0.750	1 1/8	3/4	0.734	1/4	9/16	0.562	1	

HEX SOCKET FLAT HEAD SCREWS

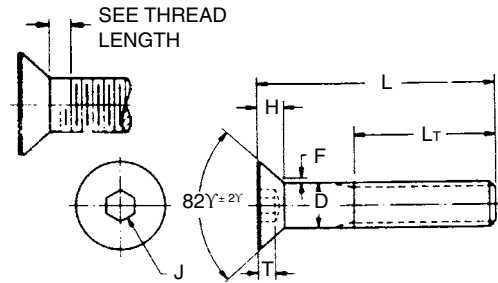
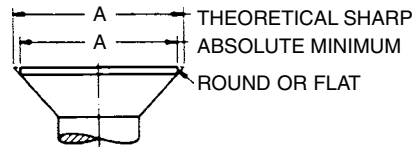

Nominal Size or Basic Screw Diameter	D Body Diameter		A Head Diameter		H Head Height		J Hexagon Socket Size		T Key Engagement	F Fillet Extension Above D Max.	Lt Basic Thread Length	
			Theoretical Sharp	Abs. Min.	Reference	Flushness Tolerance						
	Max.	Min.	Max.				Nom.	Max.	Max.	Min.		
4	0.1120	0.1120	0.1075	0.255	0.218	0.083	0.011	1/16	0.062	0.055	0.012	0.750
5	0.1250	0.1250	0.1202	0.281	0.240	0.090	0.012	5/64	0.078	0.061	0.014	0.750
6	0.1380	0.1380	0.1329	0.307	0.263	0.097	0.013	5/64	0.078	0.066	0.015	0.750
8	0.1640	0.1640	0.1585	0.359	0.311	0.112	0.014	3/32	0.094	0.076	0.015	0.875
10	0.1900	0.1900	0.1840	0.411	0.359	0.127	0.015	1/8	0.125	0.087	0.015	0.875
1/4	0.2500	0.2500	0.2435	0.531	0.480	0.161	0.016	5/32	0.156	0.111	0.015	1.000
5/16	0.3125	0.3125	0.3053	0.656	0.600	0.198	0.017	3/16	0.188	0.135	0.015	1.125
3/8	0.3750	0.3750	0.3678	0.781	0.720	0.234	0.018	7/32	0.219	0.159	0.015	1.250
7/16	0.4375	0.4375	0.4294	0.844	0.781	0.234	0.018	1/4	0.250	0.159	0.015	1.375
1/2	0.5000	0.5000	0.4919	0.938	0.872	0.251	0.018	5/16	0.312	0.172	0.015	1.500
5/8	0.6250	0.6250	0.6163	1.188	1.112	0.324	0.022	3/8	0.375	0.220	0.015	1.750
3/4	0.7500	0.7500	0.7406	1.438	1.355	0.396	0.024	1/2	0.500	0.220	0.015	2.000

DOWEL PINS

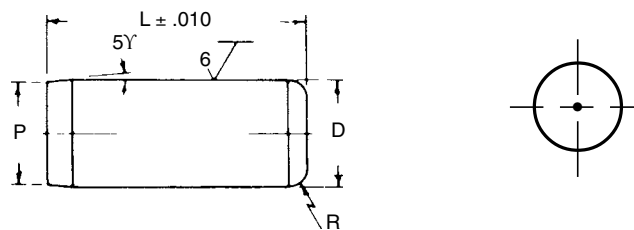

Nominal Size	D				P Point Diameter	R Top Radius	Shear Strength Double Shear (Lbs.)
	Standard Pin (.0002 over basic size)		Oversize Pin (.001 over basic size)				
	Max.	Min.	Max.	Min.	Max.		
1/8	.1253	.1251	.1261	.1259	.119	3/64	3,600
3/16	.1878	.1876	.1886	.1884	.176	3/64	8,000
1/4	.2503	.2501	.2511	.2509	.239	1/16	14,400
5/16	.3128	.3126	.3136	.3134	.301	1/16	22,400
3/8	.3753	.3751	.3761	.3759	.364	5/64	32,400
7/16	.4378	.4376	.4386	.4384	.4205	3/32	44,000
1/2	.5003	.5001	.5011	.5009	.483	7/64	57,400
5/8	.6253	.6251	.6261	.6259	.608	1/8	89,800
3/4	.7503	.7501	.7511	.7509	.728	1/8	129,200
7/8	.8753	.8751	.8761	.8759	.853	1/8	176,000
1	1.0003	1.0001	1.0001	1.0009	.978	1/8	230,000

FASTENERS
MASONRY ANCHORS
DRILLS/SAWS & ABRASIVES
TOOLS & ACCESSORIES
CONTRACTOR & INDUSTRIAL
SAFETY PRODUCTS
CHEMICALS & JANITORIAL
AUTO & ELECTRICAL
STRUT & HANGERS

HEX HEAD - HEX WASHER HEAD

MACHINE SCREWS • TAPPING SCREWS • SELF DRILLING SCREWS

FASTENERS

MASONRY ANCHORS

DRILLS/SAWS & ABRASIVES

TOOLS & ACCESSORIES

CONTRACTOR & INDUSTRIAL

SAFETY PRODUCTS

CHEMICALS & JANITORIAL

AUTO & ELECTRICAL

STRUT & HANGERS

Nominal Size	A		W		H		F		U		I		T	
	Width Across Flats		Width Across Corners		Height of Head		Diameter of Washer		Thickness of Washer		Width of Slot		Depth of Slot	
	Max.	Min.	Min.	Max.	Min.	Max.	Min.	Max.	Min.	Max.	Min.	Max.	Min.	
4	.187	.181	.202	.060	.049	.243	.225	.019	.011	.039	.031	.042	.025	
6	.250	.244	.272	.093	.080	.328	.302	.025	.015	.048	.039	.053	.033	
8	.250	.244	.272	.110	.096	.348	.322	.031	.019	.054	.045	.074	.052	
10	.312	.305	.340	.120	.105	.414	.384	.031	.019	.060	.050	.080	.057	
12	.312	.305	.340	.155	.139	.432	.398	.039	.022	.067	.056	.103	.077	
14	.375	.367	.409	.190	.172	.520	.480	.050	.030	.075	.064	.111	.083	
1/4	.375	.367	.409	.190	.172	.520	.480	.050	.030	.075	.064	.111	.083	
5/16	.500	.489	.545	.230	.208	.676	.624	.055	.035	.084	.072	.134	.100	

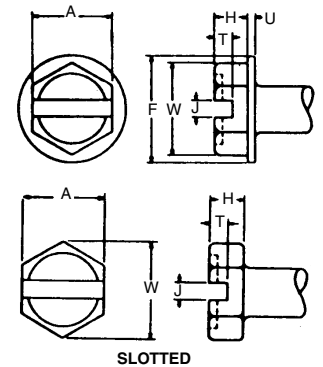

FLAT HEAD

MACHINE SCREWS • WOOD SCREWS • TAPPING SCREWS

Basic Screw Diameter	A		H	J		T	
	Head Diameter			Slot Width		Slot Depth	
	Max. Edge Sharp	Min. Edge Round or Flat	Ref.	Max.	Min.	Max.	Min.
0000	0.043	0.037	0.011	0.008	0.004	0.007	0.003
000	0.064	0.058	0.016	0.011	0.007	0.009	0.005
00	0.092	0.076	0.028	0.017	0.010	0.014	0.009
0	0.119	0.099	0.035	0.023	0.016	0.015	0.010
1	0.146	0.123	0.043	0.026	0.019	0.019	0.012
2	0.172	0.147	0.051	0.031	0.023	0.023	0.015
3	0.199	0.171	0.059	0.035	0.027	0.027	0.017
4	0.225	0.195	0.067	0.039	0.031	0.030	0.020
5	0.252	0.220	0.075	0.043	0.035	0.034	0.022
6	0.279	0.244	0.083	0.048	0.039	0.038	0.024
8	0.332	0.292	0.100	0.054	0.045	0.045	0.029
10	0.385	0.340	0.116	0.060	0.050	0.053	0.034
12	0.438	0.389	0.132	0.067	0.056	0.060	0.039
1/4	0.507	0.452	0.153	0.075	0.064	0.070	0.046
5/16	0.635	0.568	0.191	0.084	0.072	0.088	0.058
3/8	0.762	0.685	0.230	0.094	0.081	0.106	0.070
7/16	0.812	0.723	0.223	0.094	0.081	0.103	0.066
1/2	0.875	0.775	0.223	0.106	0.091	0.103	0.065
9/16	1.000	0.889	0.260	0.118	0.102	0.120	0.077
5/8	1.125	1.002	0.298	0.133	0.116	0.137	0.088
3/4	1.375	1.230	0.372	0.149	0.131	0.171	0.111

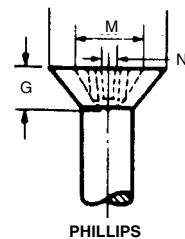
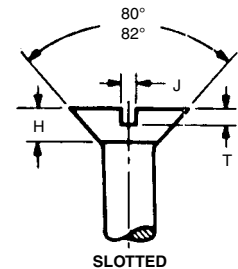

Nominal Size¹ Basic Or Screw Diameter	M		G		N	Driver Size
	Recess Diameter		Recess Depth		Recess Width	
	Max.	Min.	Max.	Min.	Min.	
0	0.0600	0.069	0.056	0.043	0.027	0
1	0.0730	0.077	0.064	0.051	0.035	0
2	0.0860	0.102	0.089	0.063	0.047	1
3	0.0990	0.107	0.094	0.068	0.052	1
4	0.1120	0.128	0.115	0.089	0.073	1
5	0.1250	0.154	0.141	0.086	0.063	2
6	0.1380	0.174	0.161	0.106	0.083	2
8	0.1640	0.189	0.176	0.121	0.098	2
10	0.1900	0.204	0.191	0.136	0.113	2

Nominal Size¹ Basic Or Screw Diameter	M		G		N	Driver Size
	Recess Diameter		Recess Depth		Recess Width	
	Max.	Min.	Max.	Min.	Min.	
12	0.2160	0.268	0.255	0.156	0.133	3
1/4	0.2500	0.283	0.270	0.171	0.148	3
5/16	0.3125	0.365	0.352	0.216	0.194	4
3/8	0.3750	0.393	0.380	0.245	0.223	4
7/16	0.4375	0.409	0.396	0.261	0.239	4
1/2	0.5000	0.424	0.411	0.276	0.254	4
9/16	0.5625	0.454	0.431	0.300	0.278	4
5/8	0.6250	0.576	0.553	0.342	0.316	5
3/4	0.7500	0.640	0.617	0.406	0.380	5

OVAL HEAD

MACHINE SCREWS • TAPPING SCREWS • WOOD SCREWS

Basic Screw Diameter	A		H	O		J		T	
	Head Diameter		Head Side Height	Total Head Height		Slot Width		Slot Depth	
	Max. Edge Sharp	Min. Edge Rounded or Flat		Ref.	Max.	Min.	Max.	Min.	Max.
00	0.093	0.083	0.028	0.042	0.034	0.017	0.010	0.023	0.016
0	0.119	0.099	0.035	0.056	0.041	0.023	0.016	0.030	0.025
1	0.146	0.123	0.043	0.068	0.052	0.026	0.019	0.038	0.031
2	0.172	0.147	0.051	0.080	0.063	0.031	0.023	0.045	0.037
3	0.199	0.171	0.059	0.092	0.073	0.035	0.027	0.052	0.043
4	0.225	0.195	0.067	0.104	0.084	0.039	0.031	0.059	0.049
5	0.252	0.220	0.075	0.116	0.095	0.043	0.035	0.067	0.055
6	0.279	0.244	0.083	0.128	0.105	0.048	0.039	0.074	0.060
8	0.332	0.292	0.100	0.152	0.126	0.054	0.045	0.088	0.072
10	0.385	0.340	0.116	0.176	0.148	0.060	0.050	0.103	0.084
12	0.438	0.389	0.132	0.200	0.169	0.067	0.056	0.117	0.096
1/4	0.507	0.452	0.153	0.232	0.197	0.075	0.064	0.136	0.112
5/16	0.635	0.568	0.191	0.290	0.249	0.084	0.072	0.171	0.141
3/8	0.762	0.685	0.230	0.347	0.300	0.094	0.081	0.206	0.170
7/16	0.812	0.723	0.223	0.345	0.295	0.094	0.081	0.210	0.174
1/2	0.875	0.775	0.223	0.354	0.299	0.106	0.091	0.216	0.176
9/16	1.000	0.889	0.260	0.410	0.350	0.118	0.102	0.250	0.207
5/8	1.125	1.002	0.298	0.467	0.399	0.133	0.116	0.285	0.235
3/4	1.375	1.230	0.372	0.578	0.497	0.149	0.131	0.353	0.293

Basic Screw Diameter	M		G		N	Driver Size
	Recess Diameter		Recess Depth		Recess Width	
	Max.	Min.	Max.	Min.	Min.	
0	0.074	0.061	0.045	0.027	0.014	0
1	0.077	0.064	0.048	0.030	0.015	0
2	0.112	0.099	0.069	0.052	0.018	1
3	0.124	0.111	0.081	0.064	0.019	1
4	0.136	0.123	0.094	0.077	0.019	1
5	0.158	0.145	0.085	0.061	0.028	2
6	0.178	0.165	0.105	0.080	0.030	2
8	0.192	0.179	0.119	0.095	0.031	2
10	0.209	0.196	0.137	0.113	0.033	2
12	0.270	0.257	0.152	0.128	0.038	3
1/4	0.290	0.277	0.173	0.148	0.040	3
5/16	0.381	0.368	0.226	0.202	0.064	4
3/8	0.400	0.387	0.245	0.221	0.066	4
7/16	0.410	0.397	0.257	0.233	0.068	4
1/2	0.422	0.409	0.269	0.245	0.070	4

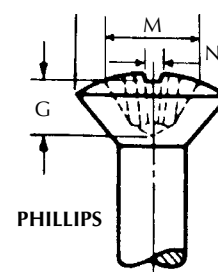
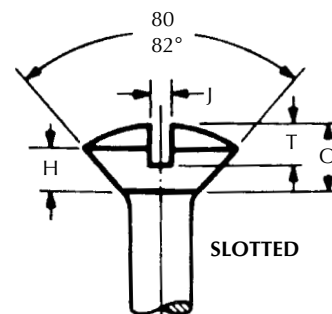

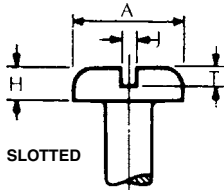

PAN HEAD
MACHINE SCREWS • TAPPING SCREWS • SELF DRILLING SCREWS

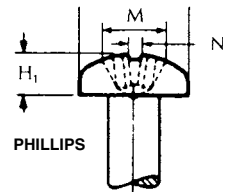

Nominal Size ¹ or Basic Screw Diameter	A Head Diameter		H Head Height (Slotted)		J Slot Width		T Slot Depth	
	Max.	Min.	Max.	Min.	Max.	Min.	Max.	Min.
0000	0.042	0.036	0.016	0.010	0.008	0.004	0.008	0.004
000	0.066	0.060	0.023	0.017	0.012	0.008	0.012	0.008
00	0.090	0.082	0.025	0.032	0.017	0.010	0.016	0.010
0	0.116	0.104	0.039	0.031	0.023	0.016	0.022	0.014
1	0.142	0.130	0.046	0.038	0.026	0.019	0.027	0.018
2	0.167	0.155	0.053	0.045	0.031	0.023	0.031	0.022
3	0.193	0.180	0.060	0.051	0.035	0.027	0.036	0.026
4	0.219	0.205	0.068	0.058	0.039	0.031	0.040	0.030
5	0.245	0.231	0.075	0.065	0.043	0.035	0.045	0.034
6	0.270	0.256	0.082	0.072	0.048	0.039	0.050	0.037
8	0.322	0.306	0.096	0.085	0.054	0.045	0.058	0.045
10	0.373	0.357	0.110	0.099	0.060	0.050	0.068	0.053
12	0.425	0.407	0.125	0.112	0.067	0.056	0.077	0.061
1/4	0.492	0.473	0.144	0.130	0.075	0.064	0.087	0.070
5/16	0.615	0.594	0.178	0.162	0.084	0.072	0.106	0.085
3/8	0.740	0.716	0.212	0.195	0.094	0.081	0.124	0.100
7/16	0.863	0.837	0.247	0.228	0.094	0.081	0.142	0.116
1/2	0.987	0.958	0.281	0.260	0.106	0.091	0.161	0.131
9/16	1.041	1.000	0.315	0.293	0.118	0.102	0.179	0.146
5/8	1.172	1.125	0.350	0.325	0.133	0.116	0.197	0.162
3/4	1.435	1.375	0.419	0.390	0.149	0.131	0.234	0.192

Nominal Size ¹ or Basic Screw Diameter	H ¹ Head Height (Recessed)		M Recess Diameter		Recess Depth		N Recess Width	Driver Size
	Max.	Min.	Max.	Min.	Max.	Min.	Min.	Size
0	0.044	0.036	0.067	0.054	0.039	0.021	0.013	0
1	0.053	0.044	0.074	0.061	0.045	0.025	0.014	0
2	0.062	0.053	0.104	0.091	0.059	0.041	0.017	1
3	0.071	0.062	0.112	0.099	0.068	0.050	0.019	1
4	0.080	0.070	0.122	0.109	0.078	0.060	0.019	1
5	0.089	0.079	0.158	0.145	0.083	0.057	0.028	2
6	0.097	0.087	0.166	0.153	0.091	0.066	0.028	2
8	0.115	0.105	0.182	0.169	0.108	0.082	0.030	2
10	0.133	0.122	0.199	0.186	0.124	0.100	0.031	2
12	0.151	0.139	0.259	0.246	0.141	0.115	0.034	3
1/4	0.175	0.162	0.281	0.268	0.161	0.135	0.036	3
5/16	0.218	0.203	0.350	0.337	0.193	0.169	0.059	4
3/8	0.261	0.244	0.389	0.376	0.233	0.210	0.065	4
7/16	0.305	0.284	0.413	0.400	0.259	0.234	0.068	4
1/2	0.348	0.325	0.435	0.422	0.280	0.255	0.071	4
9/16	0.391	0.366	0.470	0.447	0.312	0.288	0.076	4
5/8	0.434	0.406	0.587	0.564	0.343	0.314	0.081	5
3/4	0.521	0.488	0.633	0.610	0.382	0.355	0.086	5

ROUND HEAD MACHINE SCREWS • WOOD SCREWS

Basic Screw Diameter	A Head Diameter		H Head Height		J Slot Width		T Slot Depth	
	Max.	Min.	Max.	Min.	Max.	Min.	Max.	Min.
0000	0.041	0.035	0.022	0.016	0.008	0.004	0.017	0.013
000	0.062	0.056	0.031	0.025	0.012	0.008	0.018	0.012
00	0.089	0.080	0.045	0.036	0.017	0.010	0.026	0.018
0	0.113	0.099	0.053	0.043	0.023	0.016	0.039	0.029
1	0.138	0.122	0.061	0.051	0.026	0.019	0.044	0.033
2	0.162	0.146	0.069	0.059	0.031	0.023	0.048	0.037
3	0.187	0.169	0.078	0.067	0.035	0.027	0.053	0.040
4	0.211	0.193	0.086	0.075	0.039	0.031	0.058	0.044
5	0.236	0.217	0.095	0.083	0.043	0.035	0.063	0.047
6	0.260	0.240	0.103	0.091	0.048	0.039	0.068	0.051
8	0.309	0.287	0.120	0.107	0.054	0.045	0.077	0.058
10	0.359	0.334	0.137	0.123	0.060	0.050	0.087	0.065
12	0.408	0.382	0.153	0.139	0.067	0.056	0.096	0.073
1/4	0.472	0.443	0.175	0.160	0.075	0.064	0.109	0.082
5/16	0.590	0.557	0.216	0.198	0.084	0.072	0.132	0.099
3/8	0.708	0.670	0.256	0.237	0.094	0.081	0.155	0.117
7/16	0.750	0.707	0.328	0.307	0.094	0.081	0.196	0.148
1/2	0.813	0.766	0.355	0.332	0.106	0.091	0.211	0.159
9/16	0.938	0.887	0.410	0.385	0.118	0.102	0.242	0.183
5/8	1.000	0.944	0.438	0.411	0.133	0.116	0.258	0.195
3/4	1.250	1.185	0.547	0.516	0.149	0.131	0.320	0.242

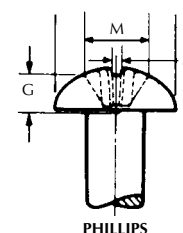
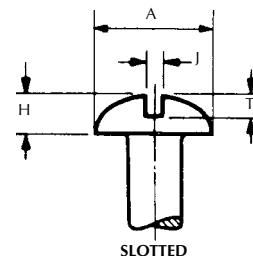

Basic Screw Diameter	M Recess Diameter		G Recess Depth		N Recess Width	Driver Size
	Max.	Min.	Max.	Min.	Min.	
0	0.073	0.060	0.042	0.022	0.014	0
1	0.082	0.069	0.052	0.033	0.015	0
2	0.100	0.087	0.053	0.034	0.017	1
3	0.109	0.096	0.062	0.042	0.018	1
4	0.118	0.105	0.072	0.053	0.019	1
5	0.154	0.141	0.074	0.046	0.027	2
6	0.162	0.149	0.084	0.056	0.027	2
8	0.178	0.165	0.101	0.075	0.030	2
10	0.195	0.182	0.119	0.093	0.031	2

Basic Screw Diameter	M Recess Diameter		G Recess Depth		N Recess Width	Driver Size
	Max.	Min.	Max.	Min.	Min.	
12	0.249	0.236	0.125	0.099	0.032	3
1/4	0.268	0.255	0.147	0.121	0.034	3
5/16	0.308	0.295	0.187	0.161	0.040	3
3/8	0.387	0.374	0.228	0.202	0.064	4
7/16	0.402	0.389	0.241	0.216	0.066	4
1/2	0.416	0.403	0.256	0.231	0.068	4
9/16	0.459	0.436	0.292	0.265	0.075	4
5/8	0.554	0.531	0.318	0.277	0.077	5
3/4	0.654	0.631	0.418	0.379	0.088	5



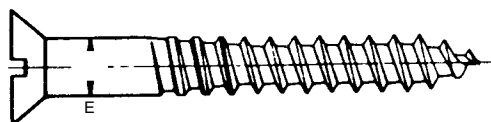

WOOD SCREWS

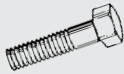

Nominal Size or Basic Screw Diameter	Threads Per Inch	E Body Diameter		
		Max.	Min.	
4	0.112	22	0.116	0.105
5	0.125	20	0.129	0.118
6	0.138	18	0.142	0.131
7	0.151	16	0.155	0.144
8	0.164	15	0.168	0.157
9	0.177	14	0.181	0.170
10	0.190	13	0.194	0.183
12	0.216	11	0.220	0.209
14	0.242	10	0.246	0.235

FASTENERS
 MASONRY ANCHORS
 DRILLS/SAWS & ABRASIVES
 TOOLS & ACCESSORIES
 CONTRACTOR & INDUSTRIAL
 SAFETY PRODUCTS
 CHEMICALS & JANITORIAL
 AUTO & ELECTRICAL
 STRUT & HANGERS

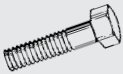
FASTENER HOLE GUIDE

FASTENERS	Drill This Size Hole				Drill This Size Hole				Drill This Size Hole		To Tap For This Size Bolt or Screw					
	Drill Size	Dec. Equiv.	To Tap For This Size Bolt or Screw	For This Size Wood Screw Pilot In Hard Wood	Drill Size	Dec. Equiv.	To Tap For This Size Bolt or Screw	For This Size Wood Screw Pilot In Hard Wood	Drill Size	Dec. Equiv.						
MASONRY ANCHORS	60	.0400	0 - 80		9/64	.1406	9 - 30 3/16 - 24 10 - 24	No. 14	E	.2500	5/16 - 18					
	59	.0410			F	.2570										
	58	.0420			G	.2610										
	57	.0430			17/64	.2656										
	56	.0465			H	.2660										
	3/64	.0469			I	.2720										
	55	.0520			J	.2770										
	54	.0550			K	.2810										
	53	.0595			1 - 64 - 72	.2812										
	1/16	.0625			No. 3	.2900										
DRILLS/SAWS & ABRASIVES	52	.0635	1 - 56 1 - 64 - 72	No. 3	22	.1570	10 - 30 10 - 32 3/16 - 32	No. 16	L	.2900	5/16 - 24					
	51	.0670			19	.1660										
	50	.0700			18	.1695										
	49	.0730			11/64	.1719										
	48	.0760			No. 4	.1730										
	5/64	.0781			No. 5	.1770										
	47	.0785			2 - 56-64	.1800										
	46	.0810			No. 6	.1820										
	45	.0820			3 - 48	.1850										
	44	.0860			No. 7	.1875										
TOOLS & ACCESSORIES	43	.0890	3 - 56 4 - 36 4 - 40 4 - 48	No. 7	3/16	.1890	12 - 24 12 - 28 12 - 32	No. 18	O	.3160	3/8 - 16					
	42	.0935			12	.1890										
	3/32	.0937			11	.1910										
	41	.0960			10	.1935										
	40	.0980			9	.1960										
	39	.0995			8	.1990										
	38	.1015			7	.2010										
	37	.1040			No. 8	.2031										
	36	.1069			5 - 36	.2040										
	7/64	.1094			No. 9	.2055										
CONTRACTOR & INDUSTRIAL	35	.1100	5 - 40 5 - 44	No. 9	13/64	.2090	1/4 - 20 1/4 - 24 1/4 - 28 1/4 - 32	No. 20	V	.3770	7/16 - 14					
	34	.1110			6	.2130										
	33	.1130			5	.2187										
	32	.1160			4	.2210										
	31	.1200			3	.2280										
	1/8	.1250			7/32	.2340										
	30	.1285			2	.2380										
	29	.1360			No. 10	.2420										
	28	.1405			No. 11	.2460										
					No. 12	.2500										
SAFETY PRODUCTS			6 - 32 6 - 36 6 - 40	No. 10	1	.2280	No. 24	No. 24	W	.3860	1/2 - 12-13					
					A	.2340										
					15/64	.2344										
					B	.2380										
					C	.2420										
					D	.2460										
					1/4	.2500										
									X	.3970						
									Y	.4040						
									Z	.4130						
				27/64	.4219											
CHEMICALS & JANITORIAL			7 - 36 8 - 30 8 - 32-36 8 - 40	No. 11	7/16	.4375	No. 20	No. 20	29/64	.4531	1/2 - 20					
					15/32	.4687										
					31/64	.4844										
					1/2	.5000										
									15/32	.4687						
									31/64	.4844						
									1/2	.5000						

*All Tap Drill Sizes are for 75% Full Thread Except Asterisked Sizes which are 60% Full Thread

METRIC CONVERSION GUIDE

CONVERSION OF METRIC UNITS OF MEASURE INTO CUSTOMARY EQUIVALENTS

TO CONVERT FROM	TO	MULTIPLY BY
Millimeters (mm)	Inches (in.)	3.937×10^{-2}
Meters (m)	Inches (in.)	3.937×10
Square Millimeters (mm ²)	Square Inches (in. ²)	1.55×10^{-3}
Square Meters (m ²)	Square Inches (in. ²)	1.55×10^3
Cubic Millimeters (mm ³)	Cubic Inches (in. ³)	6.10234×10^{-5}
Cubic Meters (m ³)	Cubic Inches (in. ³)	6.10234×10^4
Grams (g)	Ounces (avdp) (oz)	3.527×10^{-2}
Kilograms (kg)	Pounds (avdp) (lb)	2.20462
Newtons (N)	Pound Force (lbf)	2.248×10^{-1}
Kilogram Force Per Square Millimeter (kgf/mm ²)	Pounds Per Square Inch (psi)	1.4223×10^3
Newton Per Square Millimeter (N/mm ²)	Pounds Per Square Inch (psi)	1.45038×10^2
Newton Per Square Meter (N/m ²)	Pounds Per Square Inch (psi)	1.45038×10^{-4}
Newton - Meter (N • m)	Ounce - Inch (oz - in.)	1.41612×10^2
Newton - Meter (N • m)	Pound - Inch (lb - in.)	8.85073
Newton - Meter (N • m)	Pound - Foot (lb - ft)	7.3756×10^{-1}
Degree Fahrenheit	Degree Celsius	$t_c = (t_f - 32)/1.8$
Kelvin (K)	Degree Celsius	$t_c = t_k - 273.15$

CONVERSION OF CUSTOMARY UNITS OF MEASURE INTO METRIC EQUIVALENTS

Inches (in.)	Millimeters (mm)	2.54×10
Inches (in.)	Meters (m)	2.54×10^{-2}
Square Inches (in. ²)	Square Millimeters (mm ²)	6.4516×10^2
Square Inches (in. ²)	Square Meters (m ²)	6.4516×10^{-4}
Cubic Inches (in. ³)	Cubic Millimeters (mm ³)	1.638706×10^4
Cubic Inches (in. ³)	Square Meters (m ³)	1.638706×10^{-5}
Ounces (avdp) (oz)	Kilograms (kg)	2.83495×10^{-2}
Pounds (avdp) (lb)	Kilograms (kg)	4.53592×10^{-1}
Pound Force (lbf)	Newtons (N)	4.448
Pounds Per Square Inch (psi)	Kilograms Force Per Square Millimeter (kgf/mm ²)	7.0307×10^{-4}
Pounds Per Square Inch (psi)	Newton Per Square Meter (N/m ²)	6.894757×10^3
Pounds Per Square Inch (psi)	Mega Newton Per Square Millimeter (MN/m ²)	6.894757×10^{-3}
Ounce - Inch (oz - in.)	Newton - Meter (N • m)	7.061552×10^{-3}
Pound - Inch (lb - in.)	Newton - Meter (N • m)	1.129848×10^{-1}
Pound - Foot (lb - ft)	Newton - Meter (N • m)	1.355818
Degree Celsius	Kelvin (K)	$t_k = t_c + 273.15$
Degree Fahrenheit	Kelvin (K)	$t_k = (t_f + 459.67)/1.8$
Degree Rankine	Kelvin (K)	$t_k = t_r/1.8$

ISO METRIC AND UNIFIED THREAD DESIGNATIONS

ISO Metric screw threads are designated by basic diameter and thread pitch. As an example, M 8 x 1 is a standard

ISO Metric screw thread having a basic diameter of 8 millimeters and a thread pitch of 1 millimeter. To convert an ISO Metric screw thread designation to a Unified (American) designation divide the basic diameter by 25.4 and multiply the reciprocal of the pitch by 25.4 to determine nominal size in inches and threads per inch. By so doing, M 8 x 1 becomes 0.315-25.4 UNS.

Unified screw threads are designated by nominal size and number of threads per inch. As an example, 3/4 - 10 UNC is a standard Unified screw thread having a nominal size of 3/4 inches and 10 threads per inch. To convert a Unified screw thread designation to an ISO Metric screw thread designation multiply nominal size by 25.4 and multiply the reciprocal of threads per inch by 25.4 to determine basic diameter in millimeters and pitch in millimeters. By so doing, 3/4 - 10 UNC converted to ISO Metric becomes M 19.05 x 2.54.

TAP DRILL SIZES AND PERCENTAGE OF THREADS

	TAP		DECIMAL EQUIV.	THEOR. % OF THREAD	TAP		TAP DRILL	DECIMAL EQUIV.	THEOR. % OF THREAD	TAP		TAP DRILL	DECIMAL EQUIV.	THEOR. % OF THREAD	
	NOM. SIZE	T.P.I.			NOM. SIZE	T.P.I.				NOM. SIZE	T.P.I.				
FASTENERS	0	80	56	.0465	83	1/4	28	7/32	.2188	67	7/8	12	51/64	.7969	72
			3/64	.0469	81				2	.2210	63	7/8	14	51/64	.7969
MASONRY ANCHORS	1	64	54	.0550	89	1/4	32	7/32	.2188	77			13/16	.8125	67
			53	.0595	67	5/16	18	F	.2570	77	7/8	16	13/16	.8125	77
DRILLS/SAWS & ABRASIVES	1	72	53	.0595	75			G	.2610	71	7/8	20	53/64	.8281	72
			1/16	.0625	58			17/64	.2656	65	15/16	12	55/64	.8594	72
TOOLS & ACCESSORIES	2	56	51	.0670	82	5/16	20	17/64	.2656	72	15/16	16	7/8	.8750	77
			50	.0700	69	5/16	24	I	.2720	75	15/16	20	57/64	.8906	72
CONTRACTOR & INDUSTRIAL	2	64	49	.0730	56			J	.2770	66	1	8	7/8	.8750	77
			50	.0700	79	5/16	32	9/32	.2812	77				57/64	.8906
SAFETY PRODUCTS	3	48	49	.0730	64	3/8	16	5/16	.3125	77	1	12	59/64	.9219	72
			5/64	.0781	77			O	.3160	73				15/16	.9375
CHEMICALS & JANITORIAL	3	56	47	.0785	76			P	.3230	64	1	14	59/64	.9219	84
			46	.0810	67	3/8	20	21/64	.3281	72				15/16	.9375
ELECTRICAL	4	40	46	.0810	78	3/8	24	Q	.3320	79	1	16	15/16	.9375	77
			45	.0820	73			R	.3390	67	1	20	61/64	.9531	72
STRUT & HANGERS	4	48	44	.0860	56	3/8	32	11/32	.3438	77	1-1/8	7	63/64	.9844	76
			43	.0890	71	7/16	14	U	.3680	75				1	1.0000
MASONRY ANCHORS	4	48	42	.0935	57			3/8	.3750	67	1-1/8	12	1-1/32	1.0312	87
			42	.0935	68			V	.3770	65				1-3/64	1.0469
CONTRACTOR & INDUSTRIAL	5	40	3/32	.0938	68	7/16	20	W	.3860	79	1-1/8	16	1-1/16	1.0625	77
			39	.0995	79			25/64	.3906	72	1-1/8	18	1-1/16	1.0625	87
SAFETY PRODUCTS	5	44	38	.1015	72	7/16	24	X	.3970	75	1-1/4	7	1-3/32	1.0938	84
			38	.1015	79	7/16	28	Y	.4040	72				1-7/64	1.1094
CONTRACTOR & INDUSTRIAL	6	32	37	.1040	71	1/2	13	27/64	.4219	78			1-1/8	1.1250	67
			36	.1065	78			7/16	.4375	63	1-1/4	12	1-5/32	1.1562	87
MASONRY ANCHORS	6	40	7/64	.1094	70	1/2	20	29/64	.4531	72			1-11/64	1.1719	72
			35	.1100	69	1/2	24	29/64	.4531	87	1-1/4	16	1-3/16	1.1875	77
CONTRACTOR & INDUSTRIAL	8	32	33	.1130	77	1/2	28	15/32	.4688	67	1-1/4	18	1-3/16	1.1875	87
			32	.1160	68	9/16	12	15/32	.4688	87	1-3/8	6	1-3/16	1.1875	87
ELECTRICAL	8	36	29	.1360	69			31/64	.4844	72			1-13/64	1.2031	79
			28	.1405	58	9/16	18	1/2	.5000	87				1-7/32	1.2188
CONTRACTOR & INDUSTRIAL	8	36	29	.1360	78			33/64	.5156	65			1-15/64	1.2344	65
			28	.1405	68	9/16	24	33/64	.5156	87	1-3/8	12	1-9/32	1.2812	87
MASONRY ANCHORS	10	24	9/64	.1406	68	5/8	11	17/32	.5312	79			1-19/64	1.2969	72
			25	.1495	75			35/64	.5469	66	1-3/8	16	1-5/16	1.3125	77
CONTRACTOR & INDUSTRIAL	10	32	24	.1520	70	5/8	12	35/64	.5469	72	1-3/8	18	1-5/16	1.3125	87
			23	.1540	67	5/8	18	9/16	.5625	87	1-1/2	6	1-5/16	1.3125	87
ELECTRICAL	12	24	22	.1570	81			37/64	.5781	65			1-21/64	1.3281	79
			21	.1590	76	5/8	24	37/64	.5781	87				1-11/32	1.3438
CONTRACTOR & INDUSTRIAL	12	28	20	.1610	71	11/16	12	39/64	.6094	72			1-23/64	1.3594	65
			17	.1730	79	11/16	24	41/64	.6406	87	1-1/2	12	1-13/32	1.4062	87
MASONRY ANCHORS	12	28	16	.1770	72	3/4	10	41/64	.6406	84			1-27/64	1.4219	72
			15	.1800	67			21/32	.6562	72	1-1/2	16	1-7/16	1.4375	77
CONTRACTOR & INDUSTRIAL	12	28	15	.1800	78	3/4	12	43/64	.6719	72	1-1/2	18	1-7/16	1.4375	87
			14	.1820	73	3/4	16	11/16	.6875	77	1-3/4	16	1-11/16	1.6875	77
ELECTRICAL	1/4	20	13	.1850	67	3/4	20	45/64	.7031	72	2	16	1-15/16	1.9375	77
			7	.2010	75	13/16	12	47/64	.7344	72	2-1/4	16	2-3/16	2.1875	77
CONTRACTOR & INDUSTRIAL	1/4	24	13/64	.2031	72	13/16	16	3/4	.7500	77	2-1/2	16	2-7/16	2.4375	77
			6	.2040	71	13/16	20	49/64	.7656	72	2-3/4	16	2-11/16	2.6875	77
MASONRY ANCHORS	1/4	24	5	.2055	69	7/8	9	49/64	.7656	76	3	16	2-15/16	2.9375	77
			4	.2090	76			25/32	.7812	65					

METRIC TAP DRILL SIZES AND PERCENTAGE OF THREADS

TAP	TAP DRILL	DECL. EQUIV.	THEOR. % OF THREAD	TAP	TAP DRILL	DECL. EQUIV.	THEOR. % OF THREAD	TAP	TAP DRILL	DECL. EQUIV.	THEOR. % OF THREAD
M1.6 x .35	1.25mm	.0492	77	M8 x 1	I	.2720	67	M22 x 1.5	20.5mm	.8071	77
	1.3mm	.0512	66		7mm	.2756	77		13/16	.8125	70
	#55	.0520	61		J	.2770	74		21mm	.8268	77
M1.8 x .35	1.45mm	.0571	77	M10 x 1.5	8.5mm	.3346	77	M24 x 3	27/32	.8438	66
	1.5mm	.0591	66		R	.3390	71		22mm	.8661	77
	#53	.0595	64		8.75mm	.3445	77		7/8	.8750	68
M2 x 4	1.6mm	.0630	77	M10 x 1.25	S	.3480	71	M27 x 3	24mm	.9449	77
	#52	.0635	74		13/32	.4062	74		61/64	.9531	72
M2.2 x .45	1.75mm	.0689	77	M12 x 1.75	Z	.4130	66	M27 x 2	25mm	.9843	77
	#50	.0700	72		27/64	.4219	79		63/64	.9844	77
M2.5 x .45	2.05mm	.0807	77	M12 x 1.25	11mm	.4331	62	M30 x 3.5	26.5mm	1.0433	77
	#45	.0820	71		12mm	.4724	77		1-1/16	1.0625	66
M3 x .5	2.5mm	.0984	77	M14 x 2	31/64	.4844	65	M30 x 2	28mm	1.1024	77
	#39	.0995	73		12.5mm	.4921	77		1-7/64	1.1094	70
M3.5 x .6	2.9mm	.1142	77	M14 x 1.5	1/2	.5000	67	M33 x 3.5	29.5mm	1.1614	77
	#32	.1160	71		14mm	.5512	77		1-11/64	1.1719	71
M4 x .7	3.3mm	.1299	77	M16 x 2	9/16	.5625	66	M33 x 2	31mm	1.2205	77
	3.4mm	.1339	66		14.5mm	.5709	77		1-15/64	1.2344	63
M4.5 x .75	#29	.1360	60	M16 x 1.5	37/64	.5781	68	M36 x 4	32mm	1.2598	77
	3.75mm	.1476	77		15.5mm	.6102	77		1-17/64	1.2656	74
M5 x .8	#25	.1495	72	M18 x 2.5	5/8	.6250	65	M36 x 3	1-19/64	1.2969	78
	4.2mm	.1654	77		16.5mm	.6496	77		33mm	1.2992	77
M6 x 1	#18	.1695	67	M18 x 1.5	21/32	.6562	68	M39 x 4	1-5/16	1.3125	68
	5mm	.1969	77		17.5mm	.6890	77		1-3/8	1.3750	78
M7 x 1	#8	.1990	73	M20 x 2.5	45/64	.7031	66	M39 x 3	35mm	1.3780	77
	6mm	.2362	77		18.5mm	.7283	77		1-25/64	1.3906	71
M8 x 1.25	B	.2380	74	M20 x 1.5	47/64	.7344	69	M39 x 3	36mm	1.4173	77
	6.75mm	.2657	77		19.5mm	.7677	77		1-27/64	1.4219	74
	6.8mm	.2677	74		25/32	.7812	66				

PIPE TAP DRILL SIZES

TAP SIZE	• NPT		• NPTF		• STRAIGHT	
	TAP DRILL	DECIM. EQUIV.	TAP DRILL	DECIM. EQUIV.	TAP DRILL	DECIM. EQUIV.
1/16	D	.2460	D	.2460	1/4	.2500
1/8	Q	.3320	R	.3390	11/32	.3438
1/4	7/16	.4375	7/16	.4375	7/16	.4375
3/8	9/16	.5625	37/64	.5781	37/64	.5781
1/2	45/64	.7031	45/64	.7031	23/32	.7188
3/4	29/32	.9062	59/64	.9219	59/64	.9219
1	1-9/64	1.1406	1 -5/32	1.1562	1 -5/32	1.1562
1-1/4	1-31/64	1.4844	1-1/2	1.5000	1-1/2	1.5000
1-1/2	1-47/64	1.7344	1-47/64	1.7344	1-3/4	1.7500
2	2-13/64	2.2031	2-7/32	2.2188	2-7/32	2.2188
2-1/2	2-5/8	2.6250	2-41/64	2.6408	2-21/32	2.6562
3			3-17/64	3.2656		

• FOR TAPPING WITHOUT REAMING